

UNITED ALABASTER



"LIGHT IS NOT SO MUCH SOMETHING THAT
REVEALS, AS IT IS ITSELF THE REVELATION"

JAMES TURRELL



One of the most significant testimonies of the prestige enjoyed by the aragonés alabaster outside our borders, belongs to the visit that Nicolás de Satarem -Nicolau de Chanterenne- “imaginary king of Portugal“ -John III- paid to the Gelsa quarries in the early 1528, where he bought fifty cartloads of such material.

At United Alabaster, we have gathered together the traditional craftsmen and sculpture artists who have worked this natural stone for a long time. They have adapted to the new technologies and market demands. We have generated a leading business in this field; our policy 'just in time' has allowed us to reach high levels of satisfaction with our clients. The prevailing life of alabaster and its extension into the worldwide market has been demonstrated through our experience at United Alabaster.

Our clients, all over the world, are our proof that this fine material is able to combine traditional handicraft perfectly with new treatments, manufactures and technologies and is adaptable to the new demands of design and applications in new architecture.

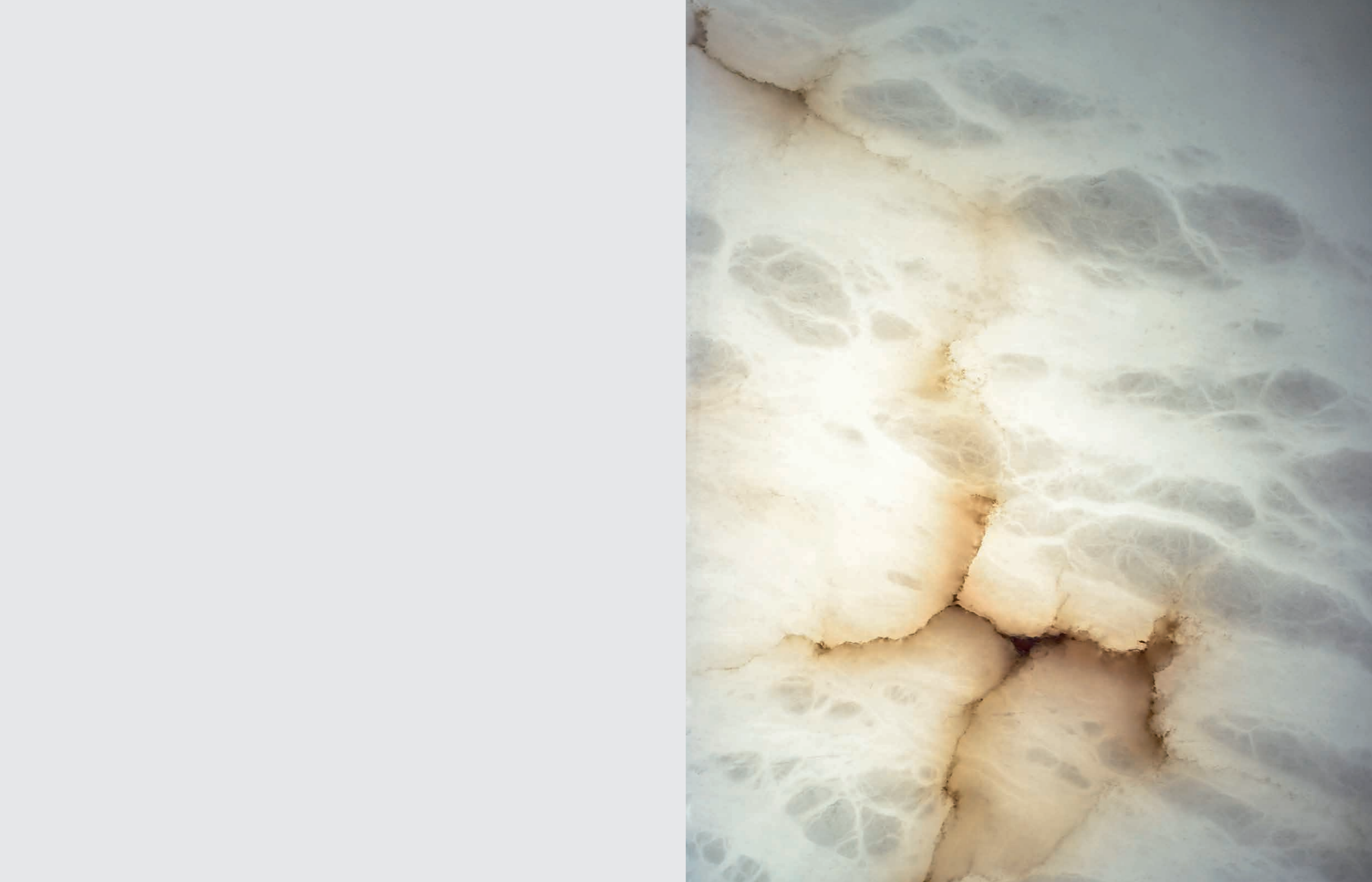

Index

12	Our History Our values	26	Alabaster Collection
16	The Origins Alabaster stone	31	Ceiling Lamp
19	The Process Albaster makers	147	Wall Lamp
22	Design Lab Custom design	175	Floor / Table Lamp
24	Showroom Madrid, meeting with Alabaster	209	Custom Design



Tradition in Alabaster since 1969

United Alabaster, located in Sarral (1969), is one of the oldest companies in Spain in the alabaster sector. It is still a family business dedicated to meeting the needs of its clients.

United Alabaster, one of the oldest companies in Spain in the alabaster sector, manufactures exclusive products to meet the needs of design and satisfy the needs of lovers of design and architectural lighting.

The company is a seal of quality and a benchmark in architecture, lighting and design.

It brings "illuminable" stone to the best international projects. In addition, it owns more than 100 mining sites from which it can extract different varieties of alabaster, thus offering an even more special product with designation of origin.

Thanks to its extensive staff, they can offer all their skills and knowledge to make exclusive design products. Our mission is to fuse this

natural stone with contemporary elements while respecting the environment and innovating in their applications. The service offered and the confidentiality of the lighting projects and architecture along with the experience gained during all these years are the key to success.

Among our products, you can find wall lights, lamps, panels, and table lamps. All of them made of first quality alabaster extracted from our quarries in La Puebla de Híjar (Teruel). Nowadays, this material surprises everybody in many interior spaces from around the world such as entrance halls, hotel rooms, restaurants, cruisers, churches or private residences, bringing warmth and harmony.



*The difference between something
good and something great is
attention to detail.*



41°23'52.4"N 0°26'41.3"W

The Stone Gelsa, Ribera Baja del Ebro

First quality alabaster extracted from the quarries in La Puebla de Híjar (Teruel) and Gelsa (Zaragoza). Born from an original vein in the quarry and moulded in their workshop.

ONE OF THE MOST SIGNIFICANT TESTIMONIES OF THE PRESTIGE ENJOYED BY THE ARAGONÉS ALABASTER OUTSIDE OUR BORDERS, BELONGS TO THE VISIT THAT NICOLÁS DE SATAREM -NICOLAU DE CHANTERENNE- "IMAGINARY KING OF PORTUGAL" -JOHN III- PAID TO THE GELSA QUARRIES IN THE EARLY 1528, WHERE HE BOUGHT FIFTY CARTLOADS OF SUCH MATERIAL.

Our production begins in our alabaster quarries in Gelsa (Zaragoza) we will place our alabaster mineral reserves at your disposal, unique in the world.

Our professional specialists in quarries locate and extract the mineral using the latest technologies established in our companies and coordinated by our office of Mining Engineers who coordinate and supervise the exploitation.

Exhaustive quality controls and the historic origin guarantee the material through its geographical location. The material extracted in large balls is sent to the sawmill where we clean and cut the material to prepare it in different formats for processing in the alabaster factories.





Our design of Alabaster articles is an example of the personalisation and exclusivity

New technologies allow us to satisfy the most creative need of our clients.

For more than 50 years, United Alabaster has got a team of people committed to their work, providing value to a natural Stone and undertaking very demanding projects using state-of-the-art machinery.

Our speciality is making articles according to the wishes and demands of the professionals at illumination projects.

The application of alabaster in new architecture allows us to make large walls for all type of shapes that will improve the elegant translucent effects of this material.

In United Alabaster process of manufacture your exacting demands are guaranteed due to the application of our technology with machines for slabbing and profiling 3D pieces in production

system. This was created to produce incredible panels with various and intricate shapes that guarantee a wide range of possibilities we carry out. Designers, developers and customers are unanimous: Alabaster is the new star.

Everything unimaginable is achieved in a white, calm and relaxing environment. The stone volumes take all the lead of the ambience where the technical staff study and develop the best creative proposal.



The manufacture of an alabaster lamp

United Alabaster process of manufacture is guaranteed due to the high technology of the state-of-the-art machinery used to develop any design, no matter how complex.

The selection of the alabaster is one of the most important decisions that our team and designers or architects make when creating a building or designing an interior. In continuous development makes collaborations with the Geologic department of the University of Zaragoza developing the alabaster I+D, positioning our company at worldwide level.

Our design of alabaster articles is an example of the personalization and exclusivity, being one of the special features of the alabaster at United Alabaster. New technologies allow us to satisfy the most exacting needs of our clients. Our specialty is making articles according to the wishes and demands of the professionals at illumination projects.

At United Alabaster you could personalize projects for hotels, restaurants, halls, enterprises so to reach pleasant and cozy corners, elegant villages, lounges or rooms. The application of alabaster in new architecture allows us to make large bowls for all type of walls that will improve the elegant translucent effects of this natural material. Our process of manufacture to your exacting demands is guaranteed due to the application of our technology W.A.C. (wide-angle cutting) in the production system.

This was created to produce incredible and large bowls with various and intricate shapes that guarantee a wide range of possibilities we carry out.



Madrid, meeting with alabaster

Explore the unique beauty of Alabaster in our showroom by Blasco in Madrid. It solidifies itself as an unmissable meeting point for professionals and clients seeking experiences beyond the conventional.

Welcome to our exclusive space in the heart of Madrid, in Salamanca district, where elegance and innovation merge to create unique experiences. In our Showroom you will be immersed in a world of exceptional design and customized solutions, all in a welcoming and avant-garde atmosphere.

We invite you to immerse yourself in the very essence of alabaster lighting. As a lamp manufacturer with a strong tradition of creating unique projects, we have taken the beauty of this natural stone to the next level.

The texture and translucency of alabaster allows it to filter light in a unique way, creating fascinating plays of light and shadow. Each piece of alabaster is unique in itself, making each alabaster lighting project an exclusive and personalized piece of work.

We will be happy to assist you and discover how to make your projects stand out.

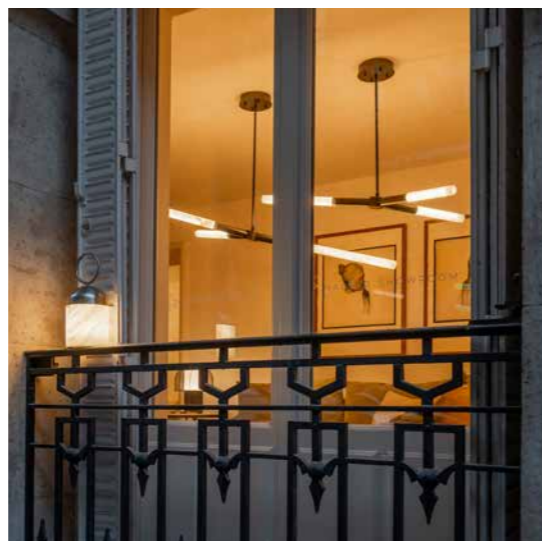

Alabaster Collection

Ceiling Lamps

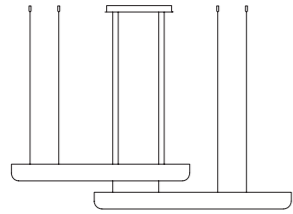

32 Halo

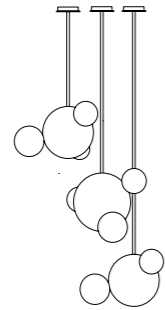

38 Up & Down

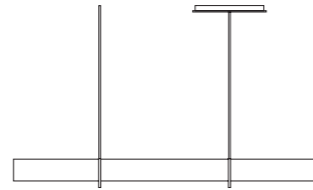

44 Super Loft

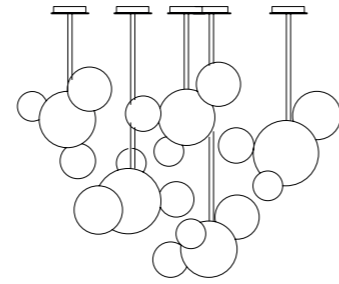

50 Up & Down Small

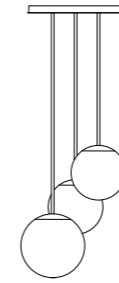

94 Moon

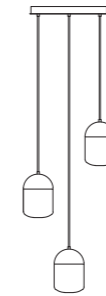

102 Glans



110 Tubular Bells

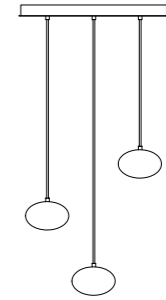

116 Oval

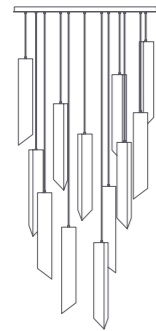

54 Triangular Tube

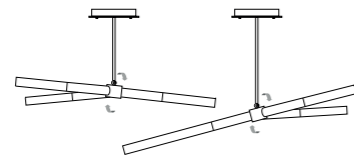

58 Ypsilon

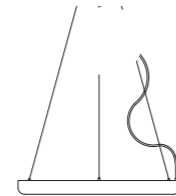

64 Ring

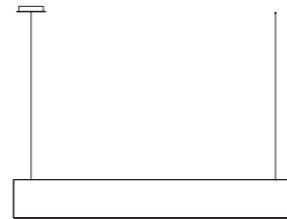

70 Tube



122 Copper

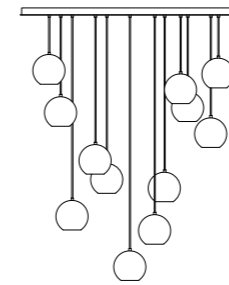

130 Rain Balls

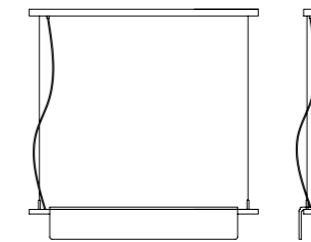

136 Loft

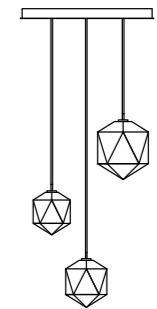

140 Meteorite

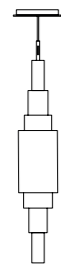

78 Kavanagh

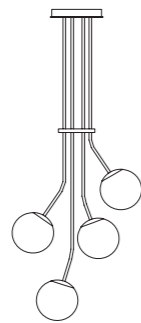

82 Berlin

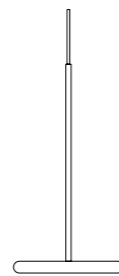

86 Nuvol



90 Balloon

Wall Lamps

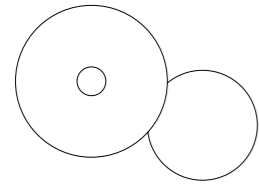

148 Nuvol WS



152 Slim WS

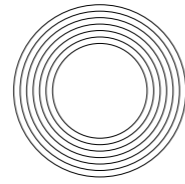

158 Mirror



162 AD1930

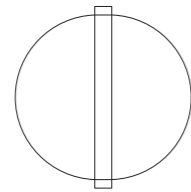

166 Slim Collection

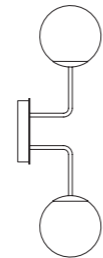

170 Berlin 2

Floor / Table Lamps

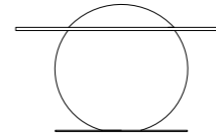

176 Solaris

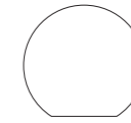

182 Wireless Moon

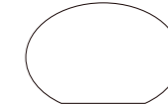

186 Wireless Oval

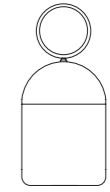

188 Wireless Glans



196 Reflex

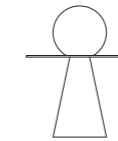

200 Saturn Cycle

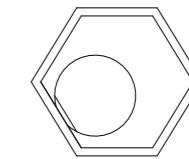

204 Hexagon

Custom Design

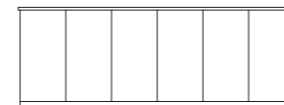

212 Wavy Desk

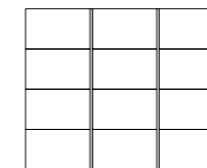

216 Panels

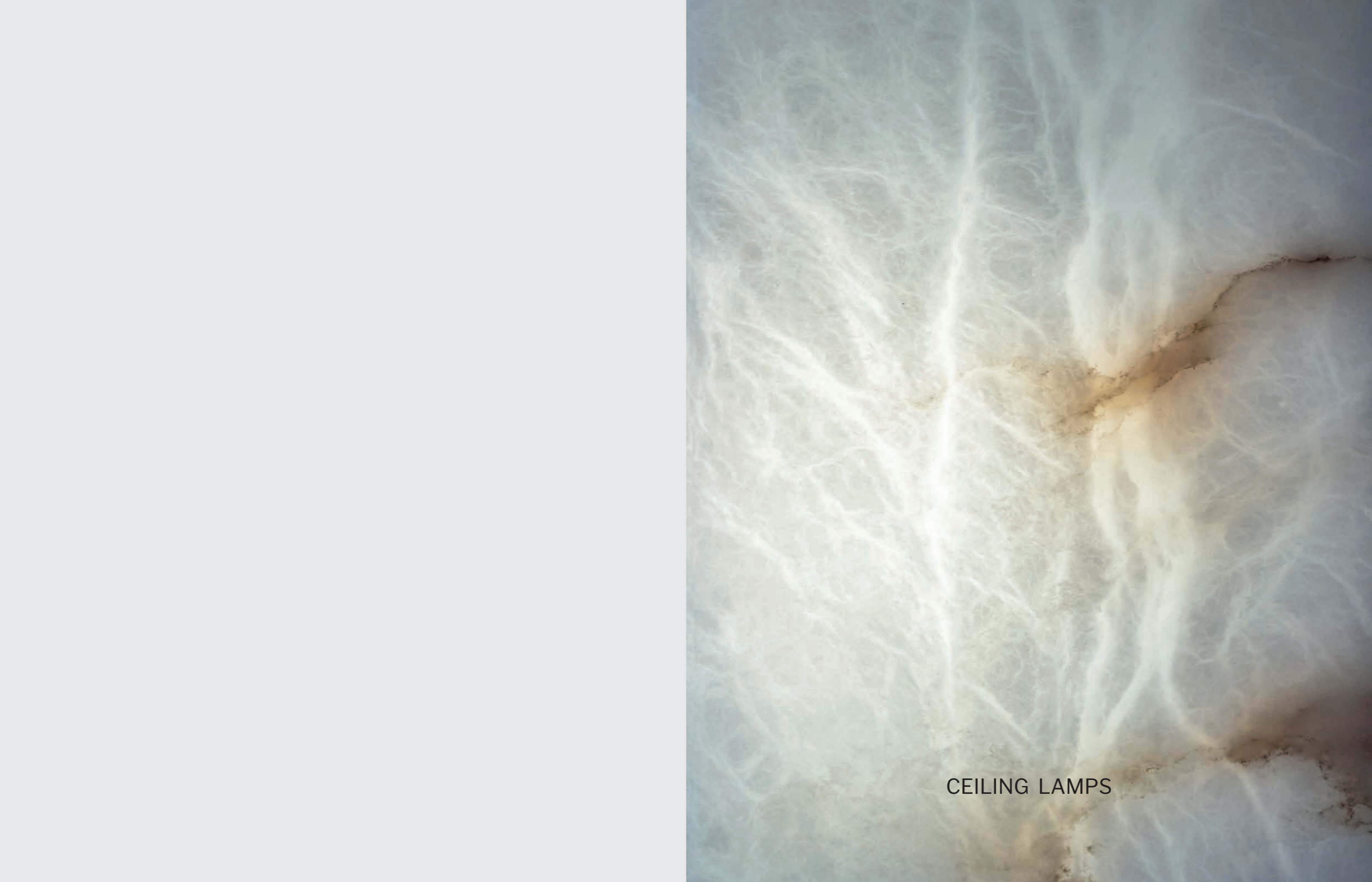

CEILING LAMPS

Halo

Ceiling Lamp

Halo with a minimalist structure, fully illuminated to appreciate all the details of each unique piece. Height adjustable suspension cables. Dimmable. By joining several luminaires, a great decorative effect is achieved with quality light.







Halo

20-8920/64 20-8920/76
Ceiling Lamp

Technical Specs

LED 25w 3000K Dimmable
LED 30w 3000K Dimmable
Driver LED strip 24v dimmable 1-10v
Color temperature: 2700K or 3000K

Size options:
49cm / 64cm / 76cm / 100cm / 120cm

Optional: Without canopy - directly to ceiling

Ceiling base

■ Matt Black (RAL 9005)

■ Matt White (RAL 9010)

Alabaster

■ White Gelsa

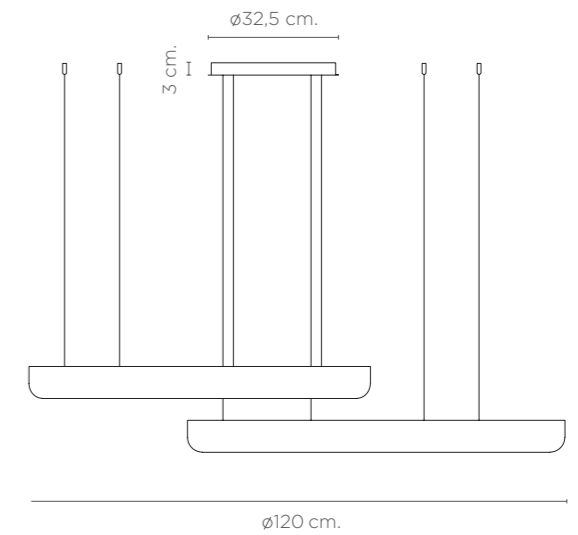

Optional

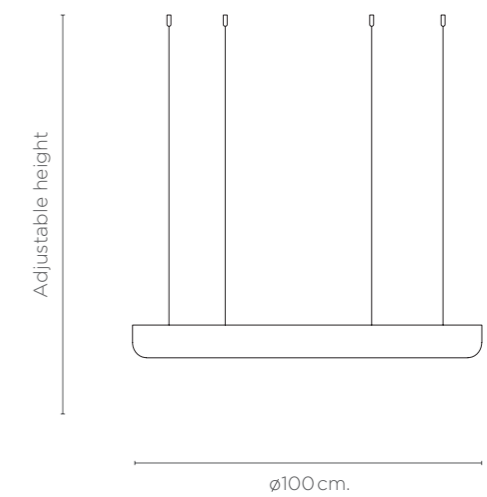



Up & Down

Ceiling Lamp

The Up & Down lamp is a work of art in natural stone, inspired by the relationship between earth and sky. This lamp is a modern interpretation of the way natural stone emerges from the earth and rises towards the sky. It is composed of 3 spheres of natural alabaster stone carefully selected from our quarries. Is presented with a vertical metal structure that extends upwards from the stone base. This metal structure holds three spheres of light that shine up and down, illuminating their surroundings and highlighting the beauty of the natural stone. The combination of natural stone and metal creates an elegant contrast in any room. The high quality natural stone is complemented by the black metal, creating a lamp that is both stunning and sophisticated.



Up & Down

20-8640/UPT
Ceiling Lamp

Technical Specs

G9 LED 4w per sphere 3000K
G9 LED 10w per sphere 3000K
230-240v and 120v
Color temperature: 2700K or 3000K

1 sphere **D. 36 cm.**
1 sphere D. 24 cm.
1 sphere D. 20 cm.
1 sphere D. 15 cm.

1 sphere **D. 32 cm.**
1 sphere D. 24 cm.
1 sphere D. 20 cm.
1 sphere D. 15 cm.

1 sphere **D. 32 cm.**
1 sphere D. 24 cm.
1 sphere D. 20 cm.

Ceiling base

- Satin Gold
- Matt Black
- Nickel
- Matt White

Structure

- Satin Gold
- Matt Black
- Nickel

Alabaster

- White Gelsa

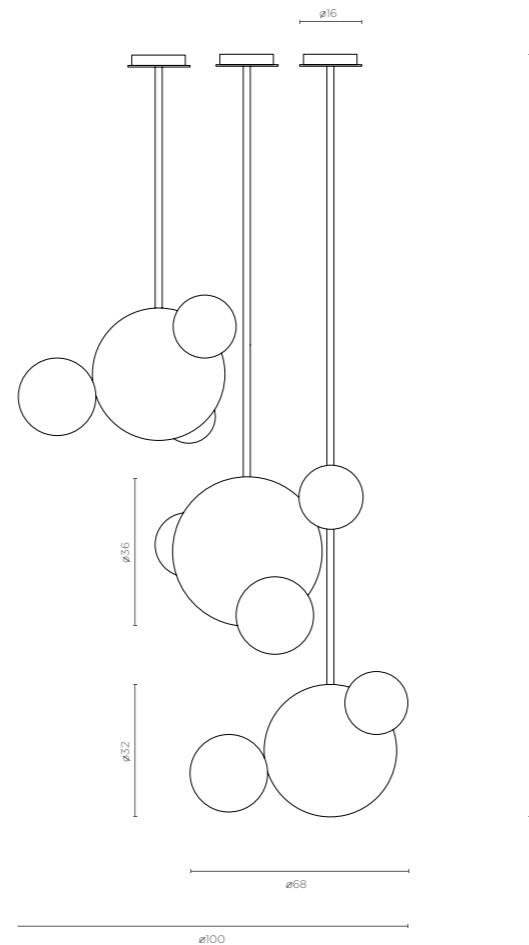

Super Loft byBlasco

Ceiling Lamp

Superloft is a piece whose design was born from the union between United Alabaster & ByBlasco. Design directed by the latter, it arises from the need to create a unique experience in a workspace. An ideal combination of technical and decorative lighting.



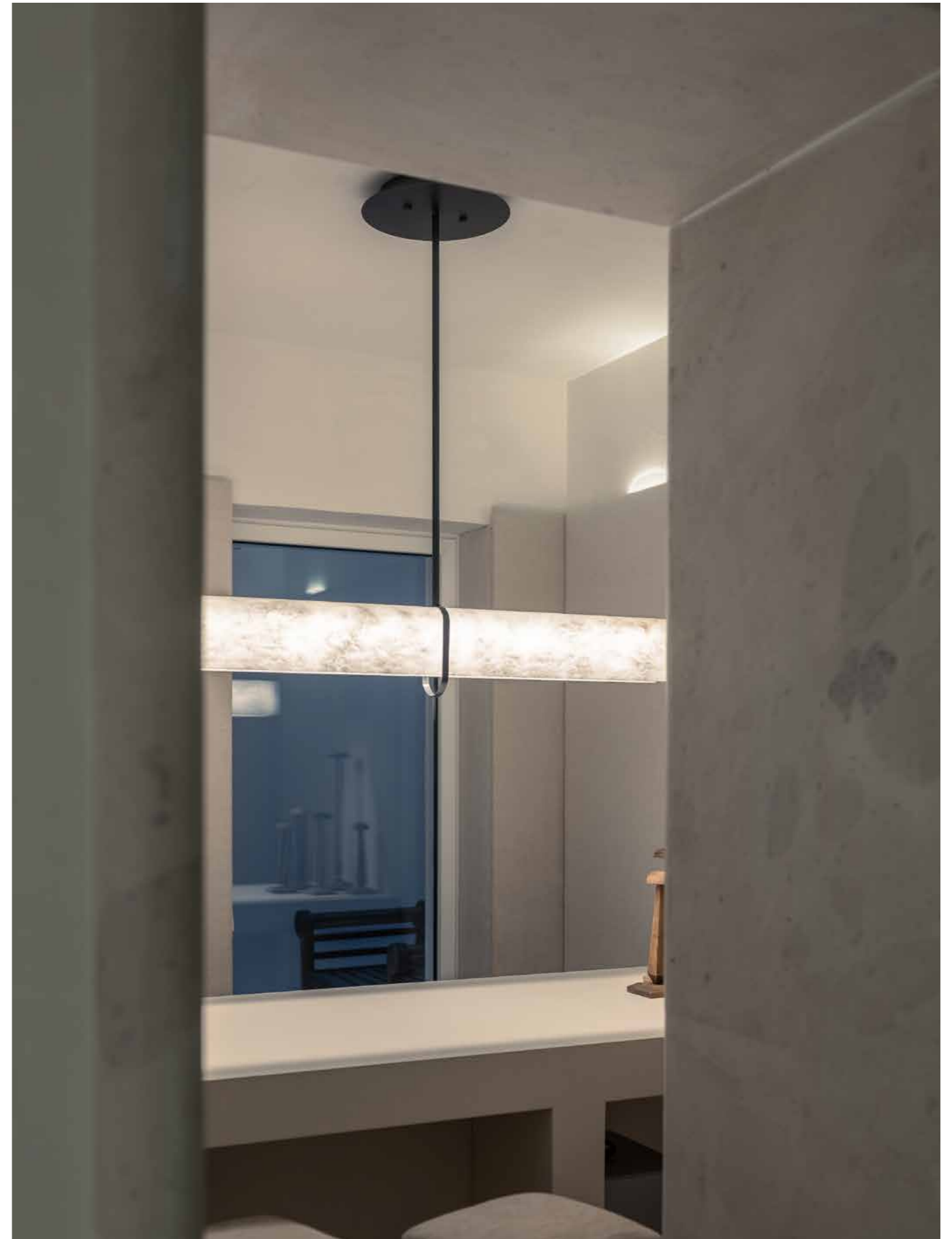

Super Loft

BLASCO
UNITED ALABASTER

20-8781
Ceiling Lamp

Technical Specs

Lineal LED 45w
Optional temperature color
2700/3000k 24v
Dimmable driver 1-10v

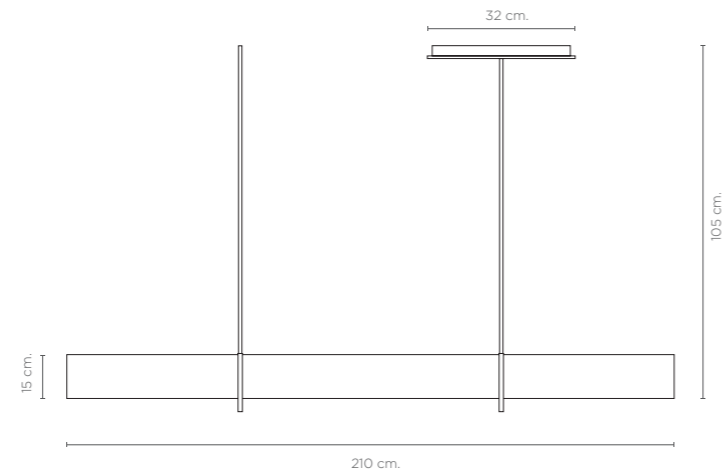

Ceiling base

- Satin Gold
- Matt Black
- Dark Brass
- Nickel
- Matt White

Structure

- Satin Gold
- Matt Black
- Dark Brass
- Nickel

Alabaster

- White Gelsa



Up & Down Small

Ceiling Lamp

The Up & Down lamp is a work of art in natural stone, inspired by the relationship between earth and sky. This lamp is a modern interpretation of the way natural stone emerges from the earth and rises towards the sky. It is composed of 3 spheres of natural alabaster stone carefully selected from our quarries.





Up & Down small

20-8650
Ceiling Lamp

Technical Specs

G9 LED 10w per sphere of D. 28 cm.
G9 LED 6w per spheres of D. 20-24 cm.
G9 LED 3w per spheres of D. 10-12-15 cm.
230-240v and 120v
Color temperature: 2700K or 3000K

UP4

1 sphere D. 24 cm.
1 sphere D. 15 cm.
1 sphere D. 12 cm.
1 sphere D. 10 cm.

UP5

1 sphere D. 28 cm.
1 sphere D. 20 cm.
1 sphere D. 15 cm.
1 sphere D. 12 cm.

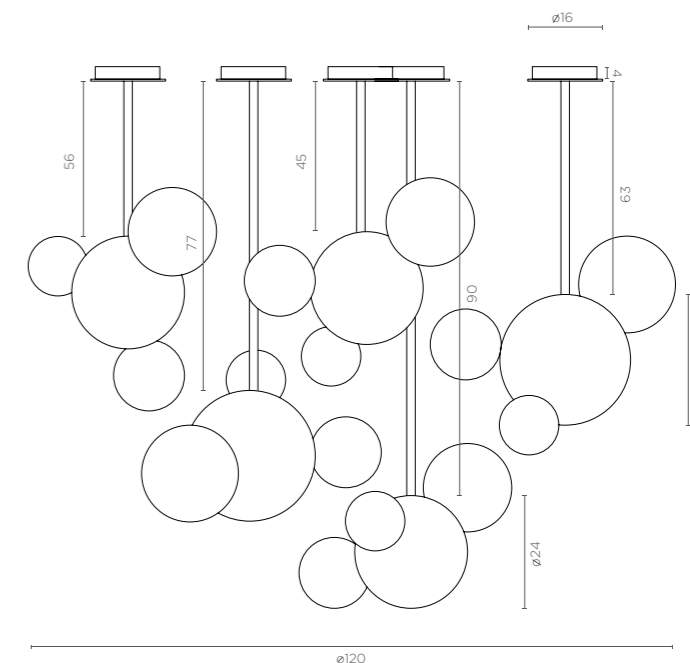

Ceiling base

- Satin Gold
- Matt Black
- Dark Brass
- Nickel
- Matt White

Structure

- Satin Gold
- Matt Black
- Dark Brass
- Nickel

Alabaster

- White Gelsa

Triangular Tube

Ceiling Lamp

The Triangular Tubes ceiling lamp is a unique and exclusive piece of art. Its triangular design and elegant structure gives it a contemporary and sophisticated style. This lamp can be composed of 12, 6 or 3 geometric elements of 60 cm length. The elements are arranged at different angles and heights to create an irregular triangular shape that extends down from the ceiling.









Triangular Tube

20-8999
Ceiling Lamp

Technical Specs

12 screen Tube D. 78 x 600 mm.
LED strip 15w
Color temperature: 2700K or 3000K
24v dimmable 1-10v

Structure

-  Nickel
-  Black Nickel
-  Gold
-  Matt White

Alabaster

-  White Gelsa

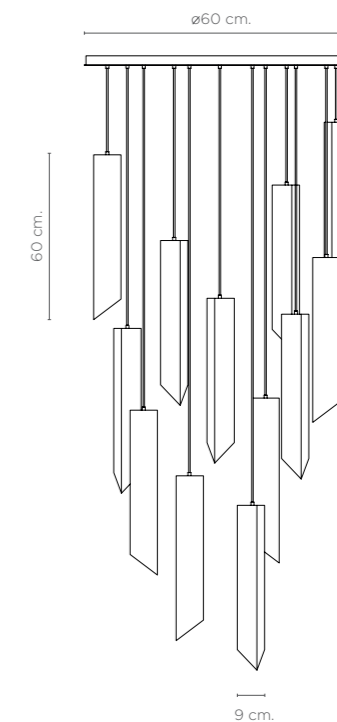

Ypsilon byBlasco

Ceiling Lamp

Ypsilon, a lamp designed by ByBlasco, takes its name from the letter Y in the Greek alphabet. In its tubes that converge on a single axis, we can see the shape of this letter. Metal and alabaster are combined in this design creating a monumental piece. In addition, its axis allows us to rotate the luminaire, giving us the possibility of adapting it to any space.





Ypsilon

20-8788
Ceiling Lamp

BLASCO
UNITED ALABASTER

Technical Specs

LED 9w | 13w | 21w
2700/3000k 24v
Dimmable driver 1-10v
CRI 90

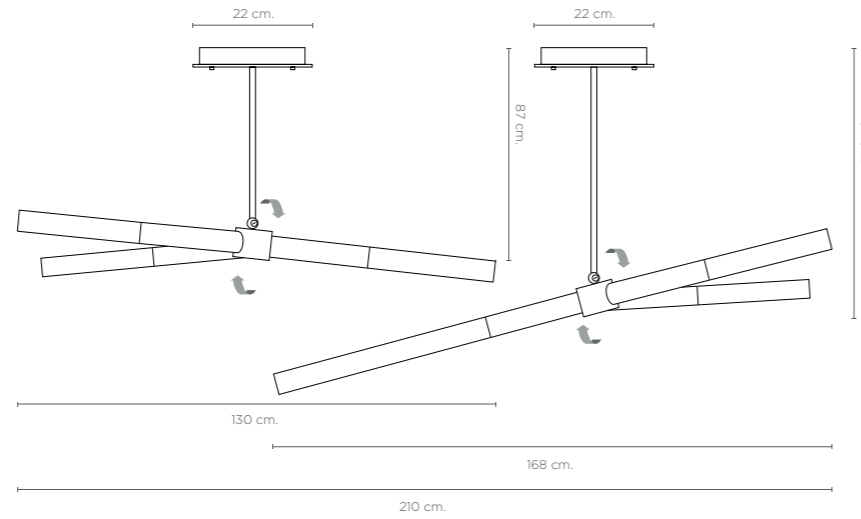

Ceiling base

- Satin Gold
- Matt Black
- Dark Brass

- Nickel
- Matt White

Structure

- Satin Gold
- Matt Black
- Dark Brass

- Nickel

Alabaster

- White Gelsa





Ring

Ceiling Lamp

A suspended alabaster ring with a minimalist structure, fully illuminated to appreciate all the details of each unique piece. Height adjustable suspension cables. Dimmable. By joining several luminaires, a great decorative effect is achieved with quality light. Designed by Joan Casanyes.



Ring

20-8910/64 20-8910/76
20-8910/100
Ceiling Lamp

Technical Specs

LED 25w 3000K Dimmable
LED 30w 3000K Dimmable
LED 35w 3000K Dimmable
Color temperature: 2700K or 3000K

Available configuration LED 2700K
Adjustable height

Size options:
49cm / 64cm / 76cm / 100cm / 120cm
and 150cm in pieces

20-8910/49

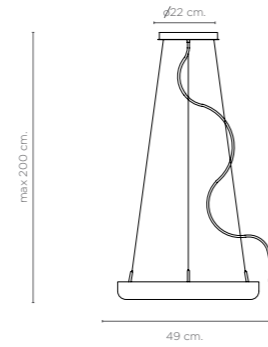

20-8910/64

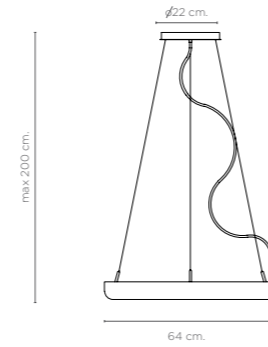

20-8910/76

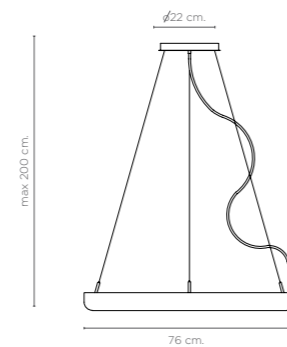

20-8910/100

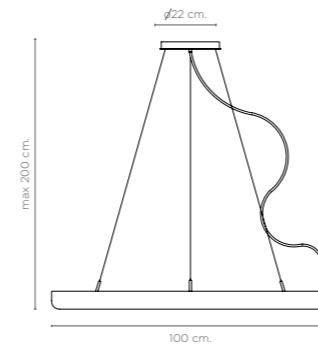



Ceiling base

-  Nickel
-  Matt Black (RAL 9005)
-  White

Alabaster

-  White Gelsa

Electrical cable

-  Black
-  White
-  Transparent



Tube

Ceiling Lamp

Tube was created in search of the horizontality of the products. The purity of alabaster in a one-piece tube with its ends finished in metal and suspended by minimalist, height-adjustable steel cables.

The light emission is 360° in order to fully enjoy the translucency of the alabaster. We have worked to avoid shadows inside the screen, emitting a very pleasant ambient light to create relaxing atmospheres.





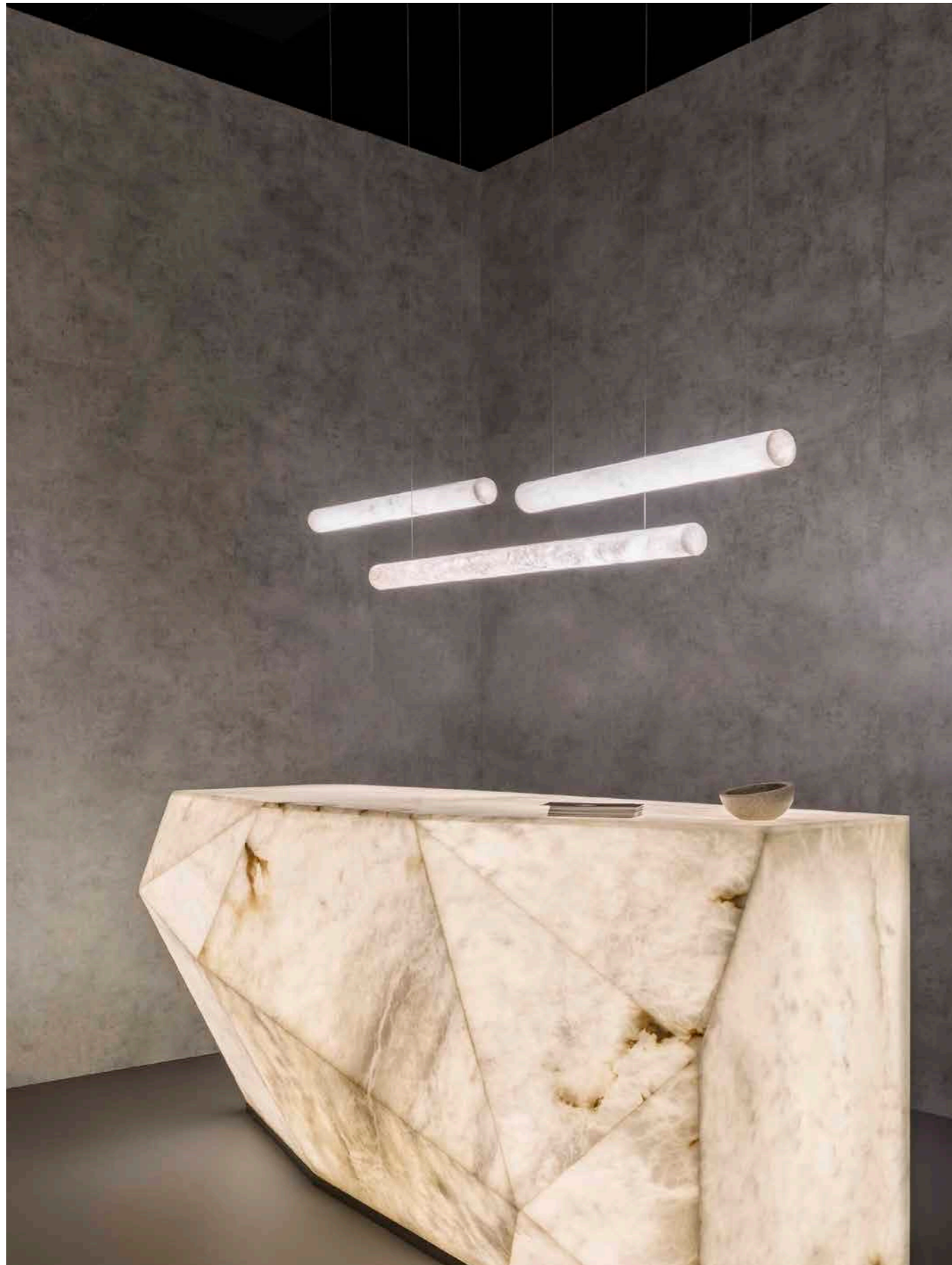

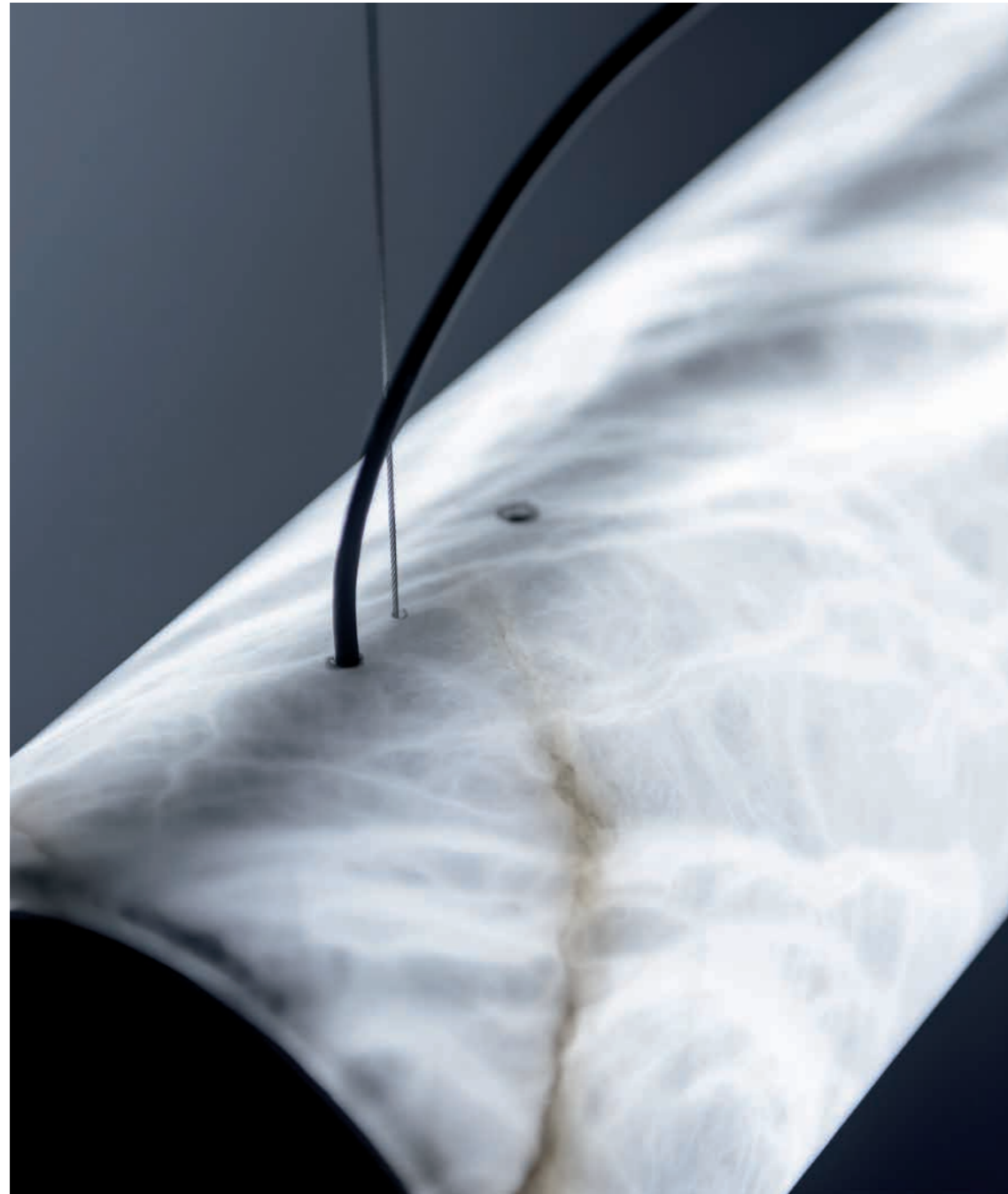

Tube

20-8940 - 20-8941
Ceiling Lamp

Technical Specs

LED strip 24w dimmable 1-10v
230-240v
Adjustable height

Size options:
D. 80 x 12 cm
D. 80 x 8 cm
D. 120 x 8 cm

Structure

- Satin Gold
- Satin Nickel
- Matt Black
- Matt White

Alabaster

- White Gelsa

20-8940

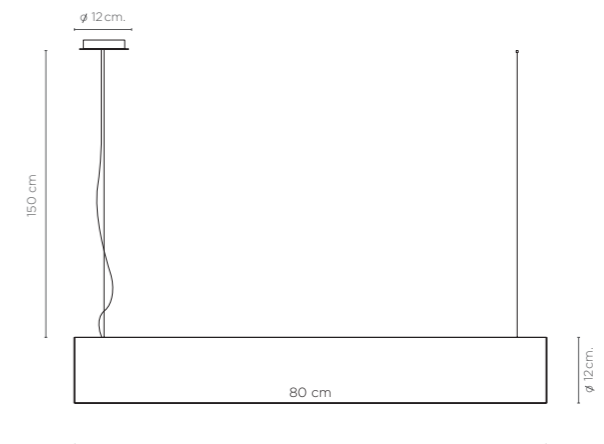

20-8941

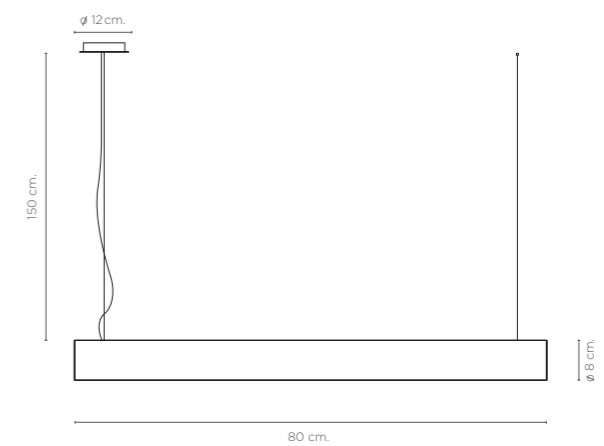

Kavanagh

Ceiling Lamp

The Kavanagh Alabaster lamp is a stunning piece of lighting that combines the elegance of 1930s Art Deco style with the natural beauty of alabaster stone.

Its staggered shape inspired design is seen in the structure of assembled tubes that create a two-way cascade of light. Designed by Joan Casanyes.







Kavanagh

20-8947
Ceiling Lamp

Technical Specs

Lineal LED 20w
Driver 24v - 230v / 120v



Structure

-  Black Nickel
-  Satin Gold
-  Satin Nickel

Alabaster

-  White Gelsa

Electrical cable

-  Black
-  Transparent
-  White

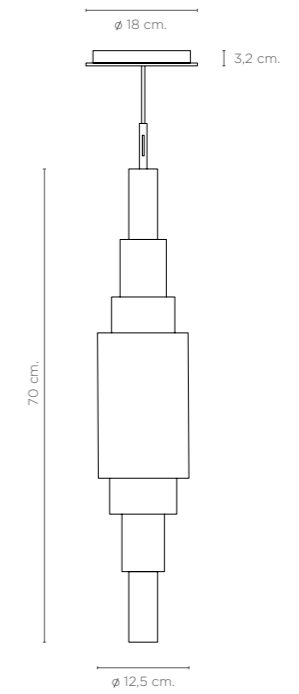

Berlin

Ceiling Lamp

With the Berlin Collection the concepts have been update by using alabaster as a diffusing material of light. Luminaires that emit a nice ambient light without high contrasts of light and shadow when they decorate any space.
Designed by Joan Casanyes.







Berlin

20-8648/4
Ceiling Lamp

Technical Specs

LED 3,5W 3000K G9
Available configuration LED 2700K
D. 56 x 152 cm

Structure

-  Satin Gold
-  Satin Nickel

Alabaster

-  White Gelsa

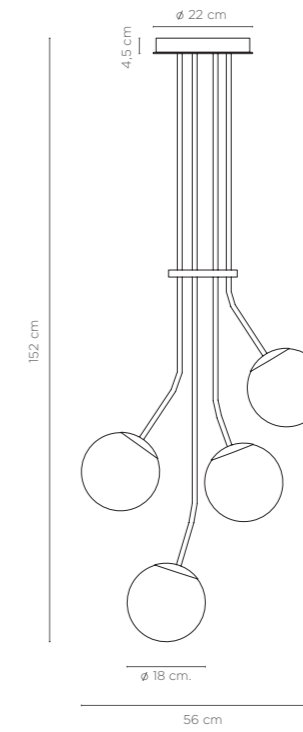



Nuvol

Ceiling Lamp

Completing the Nuvol collection, the suspension version gives a very aesthetic option. Its vertical lines and horizontal alabaster piece create a sense of lightness. Inspired by the organic shapes of nature and the clouds in the sky.

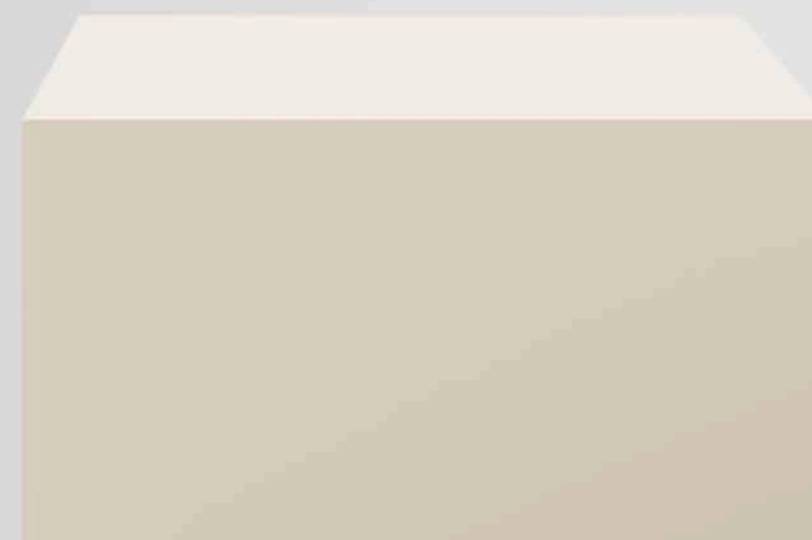
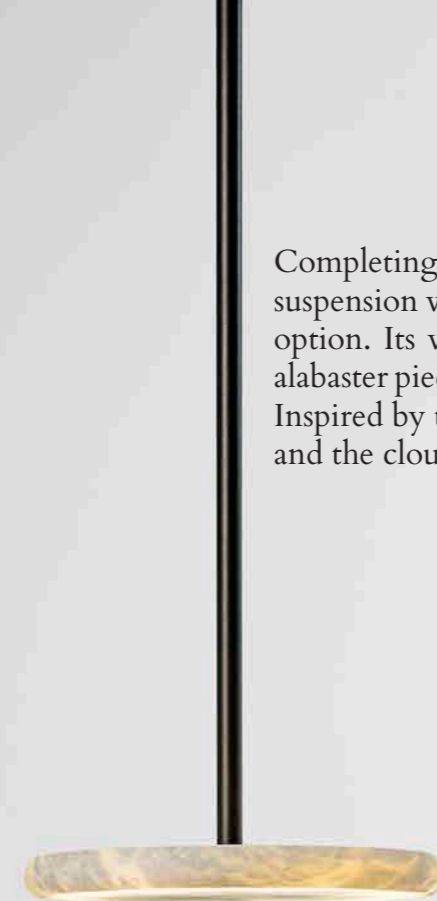





Nuvol

20-8777-1
Ceiling Lamp

Technical Specs

Compact LED 8-9LED SMD
3000K or 2700K
230-240v
12w - 8w
Dimmable TRIAC

Structure

-  Nickel
-  Black Nickel
-  Gold

Alabaster

-  White Gelsa

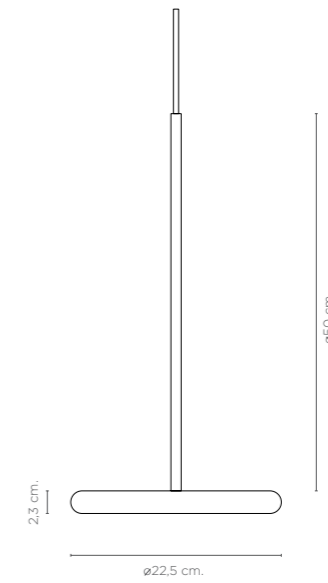

Balloon

Ceiling Lamp

The Balloon alabaster pendant lamp emits a soft ambient glow at the top and a more accentuated focal light at the opening.

Its shape is inspired by the hot air balloons of Cappadocia and all that surrounds them, the light of dawn, the natural forms of the earth, the capricious shapes of the ground carved by water and wind, reminiscent of the veins of alabaster.







Balloon

20-8643
Ceiling Lamp

Technical Specs

LED 12W 3000K E27
D. 30 x 48 cm

Structure

-  Satin Gold
-  Satin Nickel



Ceiling base

-  Matt Black
-  Matt White

Alabaster

-  White Gelsa

Electrical cable

-  Black
-  Transparent

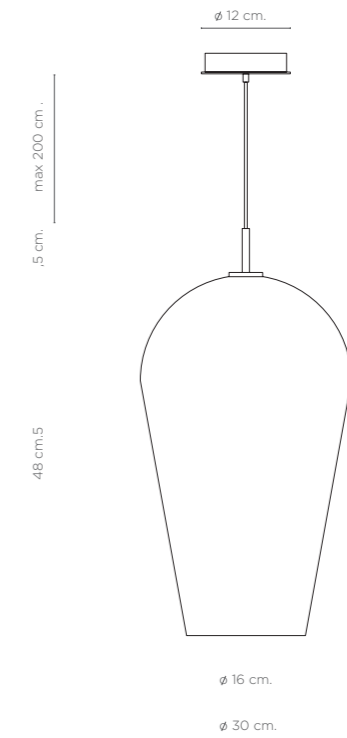

Moon

Ceiling Lamp

Moon has been designed by connecting the shapes and shadows of the satellite that illuminates our nights and resembling them with the shapes and veins of alabaster. Formats from 12 to 36 cm in diameter with infinite configuration possibilities, applied independently or together. Ceiling bases in satin steel in different metallic finishes or in oven-lacquered steel, depending on the measurements.





Moon

20-8640
Ceiling Lamp

Technical Specs

G9 LED per screen 3000K 230v
28 cm - 8w
32 cm - 10w
36 cm - 12w

Metal tube highest:
50 / 60 / 70 / 80 / 90 / 100 / 110 cm
Tube D. 1,2 cm

Ceiling base

- Satin Gold
- Nickel
- Matt Black (RAL 9005)
- Matt White (RAL 9010)

Structure

- Satin Gold
- Nickel
- Matt Black (RAL 9005)

Alabaster

- White Gelsa

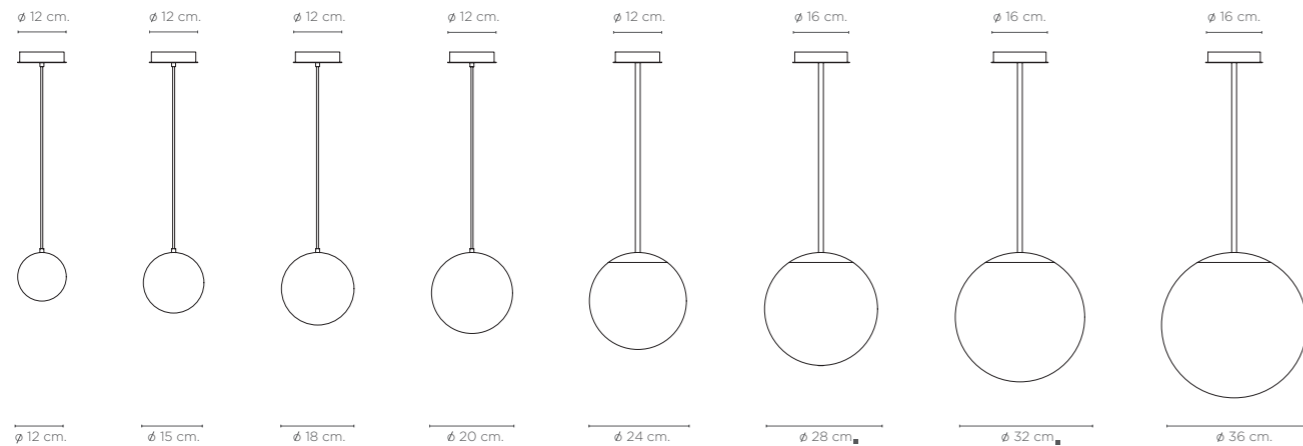

Moon3

20-8646/3
Ceiling Lamp

Technical Specs

G9 LED per screen 3000K 230v
28 cm - 8w
3 spheres D. 28 cm

Ceiling base

- Matt Black (RAL 9005)
- Matt White (RAL 9010)

Structure

- Satin Gold
- Matt Black
- Nickel

Alabaster

- White Gelsa

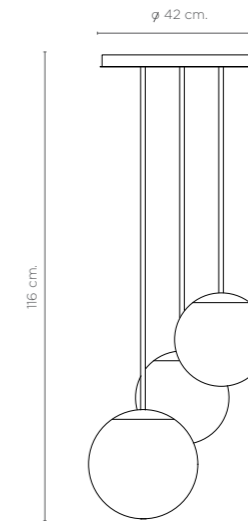



Moon6

20-8646/6
Ceiling Lamp

Technical Specs

G9 LED per screen 3000K 230v
28 cm - 8w
32 cm - 10w
36 cm - 12w

3 spheres D. 24 cm
2 spheres D. 28 cm
1 spheres D. 32 cm

Ceiling base

- Matt Black (RAL 9005)
- Matt White (RAL 9010)

Structure

- Satin Gold
- Matt Black
- Nickel

Alabaster

- White Gelsa

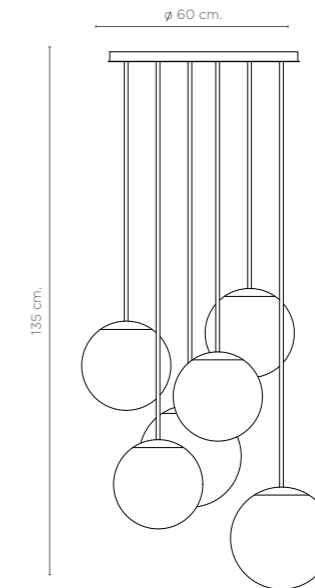

Glans

Ceiling Lamp

Glans Lamp, a suspension of organic forms, its name comes from the acorn-shaped fruit. Its shape reminds us of this voluminous, oval and somewhat pointed fruit, composed of a hard shell. They are supplied in unitary format, or in luminaires with 3, 6, 12 or more screens depending on the project. Designed by Joan Casanyes.





Glans3

20-8970/3
Ceiling Lamp

Technical Specs

3xG9 LED 3w 3000K 230v
Available configuration LED 2700K
Adjustable height

Ceiling base

- Matt Black (RAL 9005)
- Matt White (RAL 9010)

Structure

- Brushed Brass
- Brushed Copper

Alabaster

- White Gelsa

Electrical cable

- Black
- Transparent
- Black textil

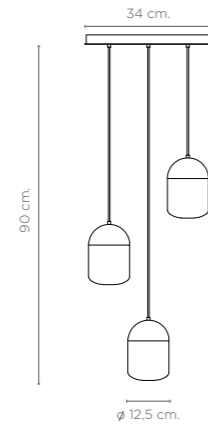

Glans6

20-8970/6
Ceiling Lamp

Technical Specs

6xG9 LED 3w 3000K 230v
Available configuration LED 2700K
Adjustable height

Ceiling base

- Matt Black (RAL 9005)
- Matt White (RAL 9010)

Structure

- Brushed Brass
- Brushed Copper
- Matt Black

Alabaster

- White Gelsa

Electrical cable

- Black
- Transparent
- Black textil

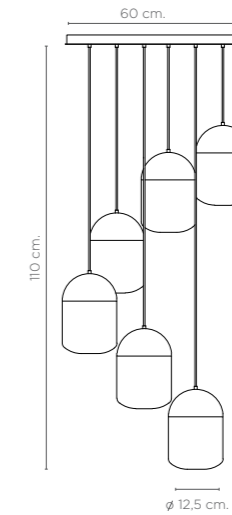

Glans12

20-8970/12
Ceiling Lamp

Technical Specs

12xG9 LED 3w 3000K 230v
Available configuration LED 2700K
Adjustable height

Ceiling base

■ Dark Grey Wood Lacquered (RAL 7005)

Structure

■ Brushed Brass

■ Brushed Copper

Alabaster

■ White Gelsa

Electrical cable

■ Black

□ Transparent

■ Black textil

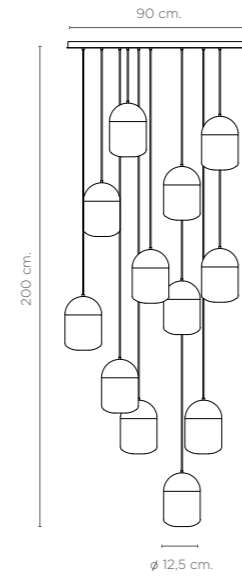

Tubular Bells

Ceiling Lamp

Set of alabaster tubes suspended at different heights creating a circular curtain of tubes. Very visual lamp that fits very well due to its height in hotel halls or in wide stairwells to dress any environment. Designed by Joan Casanyes.





Tubular Bells3

20-8900/3
Ceiling Lamp

Technical Specs

3xGU10 LED 5w 3000K 230v
Adjustable height
3 alabaster tubes
D. 7,8 x 34 cm

Ceiling base

- Matt Black (RAL 9005)
- Matt White (RAL 9010)

Structure

- Brass

Alabaster

- White Gelsa

Electrical cable

- Black textil
- Black and white textil
- Black

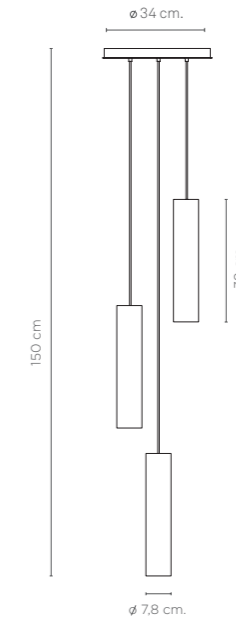

Tubular Bells6

20-8900/6
Ceiling Lamp

Technical Specs

6xGU10 LED 5w 3000K 230v
Adjustable height
6 alabaster tubes
D. 7,8 x 39 cm

Ceiling base

- Matt Black (RAL 9005)
- Matt White (RAL 9010)

Structure

- Brass

Alabaster

- White Gelsa

Electrical cable

- Black textil
- Black and white textil
- Black

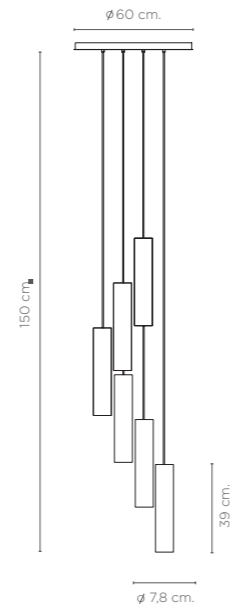

Tubular Bells12

20-8900/12
Ceiling Lamp

Technical Specs

12xGU10 LED 5w 3000K 230v
Adjustable height
12 alabaster tubes
D. 7,8 x 39 cm

Ceiling base

- Matt Black (RAL 9005)
- Matt White (RAL 9010)

Structure

- Brass

Alabaster

- White Gelsa

Electrical cable

- Black textil
- Black and white textil
- Black

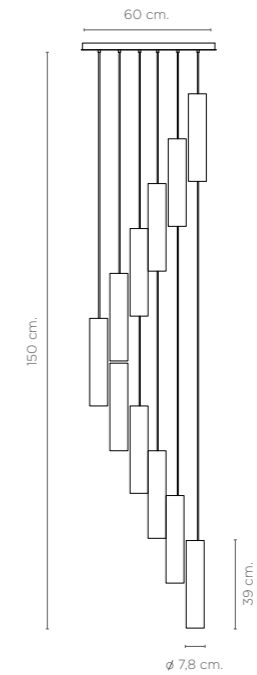

Oval

Ceiling Lamp

Lamps with oval organic shapes. The compositions of 3 or 6 screens come with oven-lacquered steel bases, in white or black. The fixing elements of the screens are made of threaded solid brass.





Oval3

20-8975/3
Ceiling Lamp

Technical Specs

3xG9 LED 3w 3000K 230v
3 oval alabaster shades 28 cm x 18 cm
Adjustable height

Ceiling base

■ Matt Black (RAL 9005)

■ Matt White (RAL 9010)

Structure

■ Brass

Alabaster

■ White Gelsa

Electrical cable

■ Black

□ Transparent

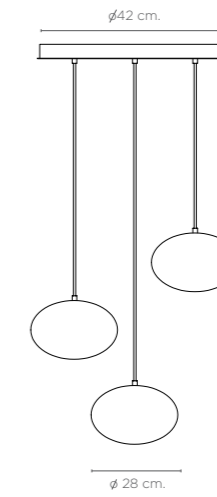

Oval6

20-8975/6
Ceiling Lamp

Technical Specs

6xG9 LED 3w 3000K 230v
6 oval alabaster shades 18 cm x 12 cm
Adjustable height

Ceiling base

■ Matt Black (RAL 9005)

■ Matt White (RAL 9010)

Structure

■ Brass

Alabaster

■ White Gelsa

Electrical cable

■ Black

□ Transparent

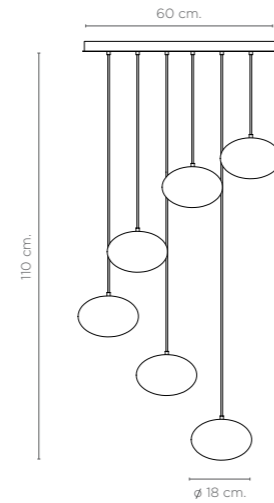

Oval12

20-8975/12
Ceiling Lamp

Technical Specs

12xG9 LED 3w 3000K 230v
12 oval alabaster shades 18 cm x 12 cm
Adjustable height

Ceiling base

■ Matt Black (RAL 9005)

■ Matt White (RAL 9010)

Structure

■ Brass

Alabaster

■ White Gelsa

Electrical cable

■ Black

□ Transparent

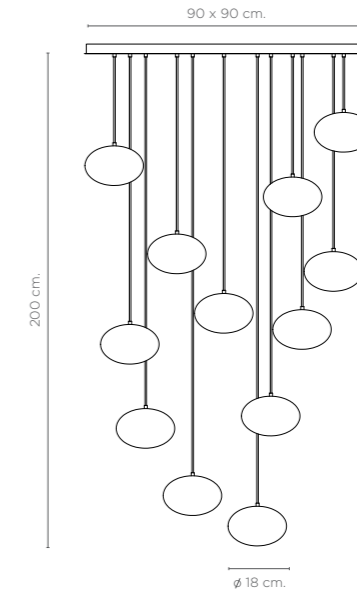

Copper

Ceiling Lamp

Old molds to repulse copper pieces, with which maritime buoys were made, have been updated and combined with alabaster. The result is a family of luminaires of different types and sizes, adaptable in any contemporary space. Copper is a noble metal, durable over time and easily recyclable. Designed by Joan Casanyes.





Copper

20-8770/18
Ceiling Lamp

Technical Specs

LED 5w per screen E27 3000K 230v
Available configuration LED 2700K
Adjustable height

Ceiling base

- Matt Black (RAL 9005)
- Matt White (RAL 9010)

Structure

- Brushed Brass
- Black Nickel
- Brushed Copper

Alabaster

- White Gelsa

Electrical cable

- Black textile
- ▨ Black & white

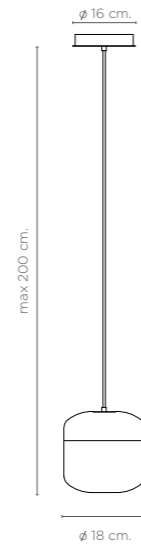

Copper6

20-8773/6
Ceiling Lamp

Technical Specs

LED 5w per screen E27 3000K 230v
Available configuration LED 2700K
Adjustable height

Ceiling base

- Matt Black (RAL 9005)
- Matt White (RAL 9010)

Structure

- Brushed Brass
- Black Nickel
- Brushed Copper

Alabaster

- White Gelsa

Electrical cable

- Black textile
- Transparent

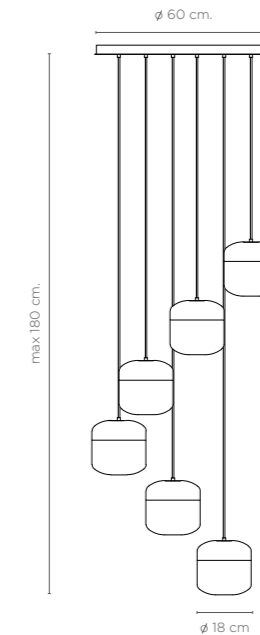



Copper3

20-8775/3
Ceiling Lamp

Technical Specs

LED 5w per screen E27 3000K 230v
Available configuration LED 2700K
Adjustable height

Ceiling base

- Matt Black (RAL 9005)
- Matt White (RAL 9010)

Structure

- Brushed Brass
- Black Nickel
- Brushed Copper

Alabaster

- White Gelsa

Electrical cable

- Black textile
- Transparent

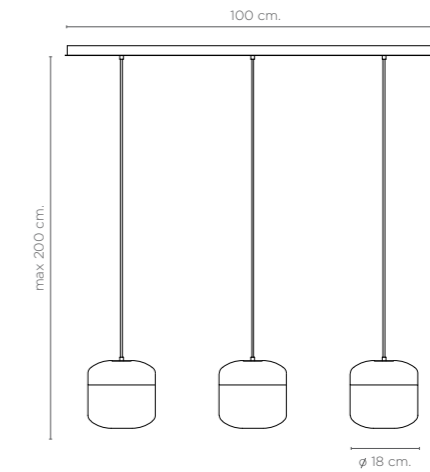

Rain Balls

Ceiling Lamp

A shower of luminous balls that spreads through space. It can illuminate from a large table, a living room or a staircase, depending on the distribution of the screens. Lacquered wood base.





Rain Balls9

20-8620/9
Ceiling Lamp

Technical Specs

9xG9 LED 3w 3000K 230v
Adjustable height
D. 60 cm
9 spheres D. 14 cm
Height 200 cm

Ceiling base

- Matt Black (RAL 9005)
- Dark Grey Wood Lacquered (RAL 7005)

Structure

- Brass

Alabaster

- White Gelsa

Electrical cable

- Black
- Transparent

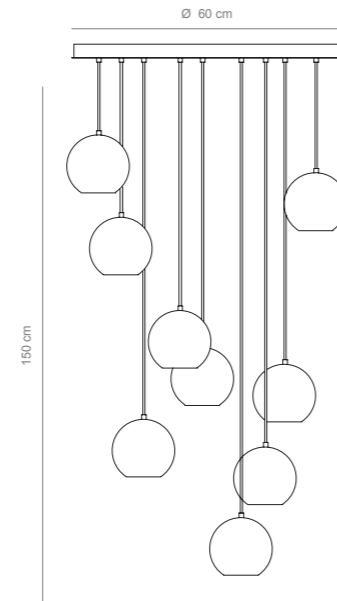

Rain Balls12

20-8620/12
Ceiling Lamp

Technical Specs

12xG9 LED 3w 3000K 230v
Adjustable height
90 x 120 cm
12 spheres D. 14 cm
Height 115 cm

Ceiling base

- Matt Black (RAL 9005)
- Dark Grey Wood Lacquered (RAL 7005)

Structure

- Brass

Alabaster

- White Gelsa

Electrical cable

- Black
- Transparent

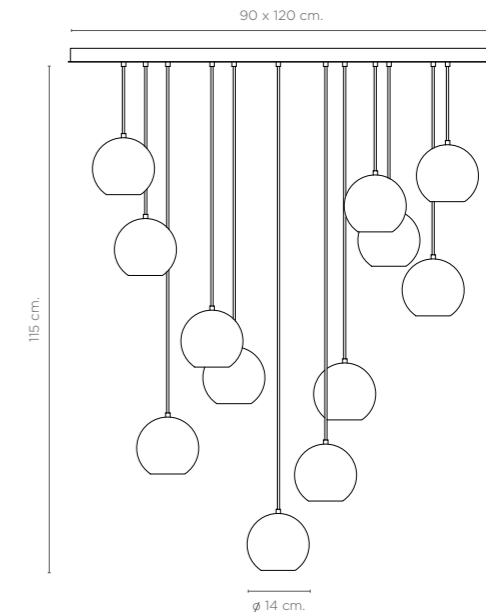

Loft

Ceiling Lamp

The Loft alabaster lamp is designed to dress any type table, from the one in the office to counteract the blue light of your screen or to dress a meeting table majestically with its veins. Classic but functional design. Designed by Joan Casanyes.





Loft

20-8780
Ceiling Lamp

Technical Specs

Lighting LED lineal 20w 3000K
Driver 30w, 230-24v

Adjustable height

Ceiling base

- Matt Black (RAL 9005)
- Matt White (RAL 9010)
- Satin Nickel

Structure

- Satin Nickel

Alabaster

- White Gelsa

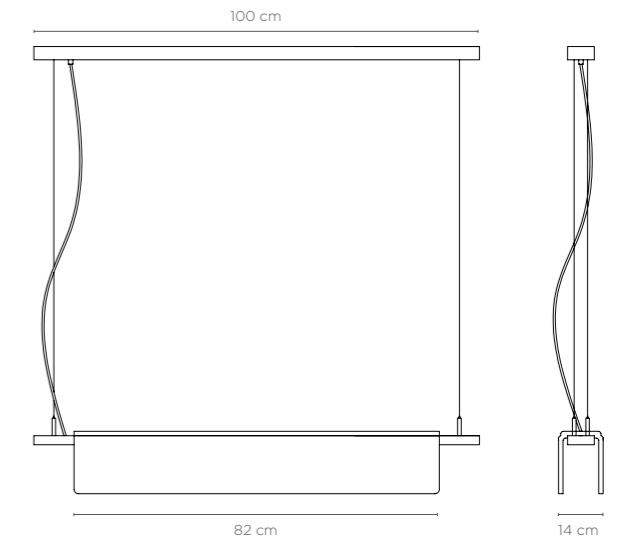

Meteorite

Ceiling Lamp

The Meteorite alabaster pendant lamp reflects a unique and personal style. Its cut, like that of a gemstone, in the shape of an icosahedron, determines the shape.





Meteorite3

20-8725/3
Ceiling Lamp

Technical Specs

3xG9 LED 3,5w 3000K 230v
Adjustable height
1 shade D. 28 cm
1 shade D. 24 cm
1 shade D. 20 cm

Ceiling base

- Matt Black (RAL 9005)
- Matt White (RAL 9010)

Structure

- Brass

Alabaster

- White Gelsa

Electrical cable

- Black textile

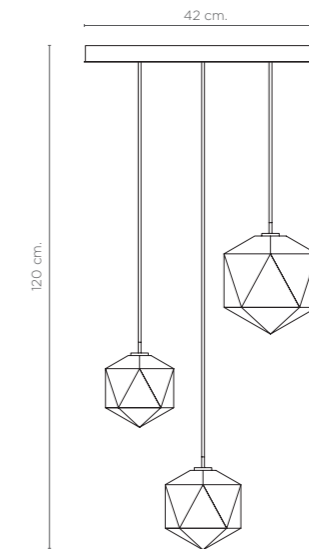

Meteorite6

20-8725/6
Ceiling Lamp

Technical Specs

6xG9 LED 3,5w 3000K 230v
Adjustable height
2 shade D. 28 cm
2 shade D. 24 cm
2 shade D. 20 cm

Ceiling base

- Matt Black (RAL 9005)
- Matt White (RAL 9010)

Structure

- Brass

Alabaster

- White Gelsa

Electrical cable

- Black textile

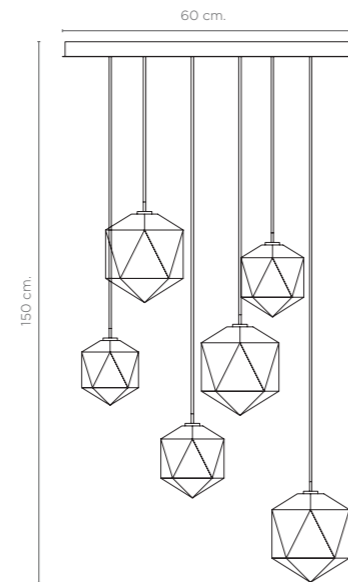

Meteorite12

20-8725/12
Ceiling Lamp

Technical Specs

12xG9 LED 3,5w 3000K 230v
Adjustable height
12 shade D. 20 cm

Ceiling base

- Matt Black (RAL 9005)
- Matt White (RAL 9010)

Structure

- Brass

Alabaster

- White Gelsa

Electrical cable

- Black textile

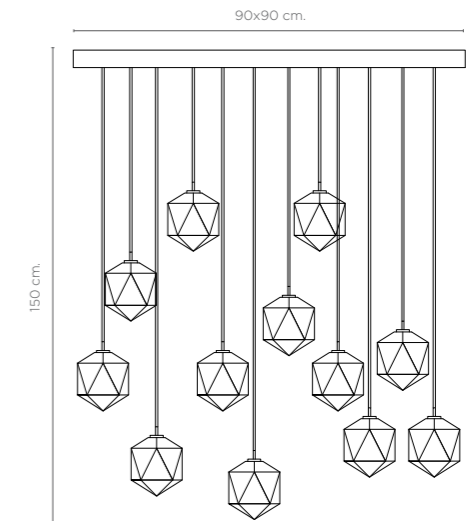

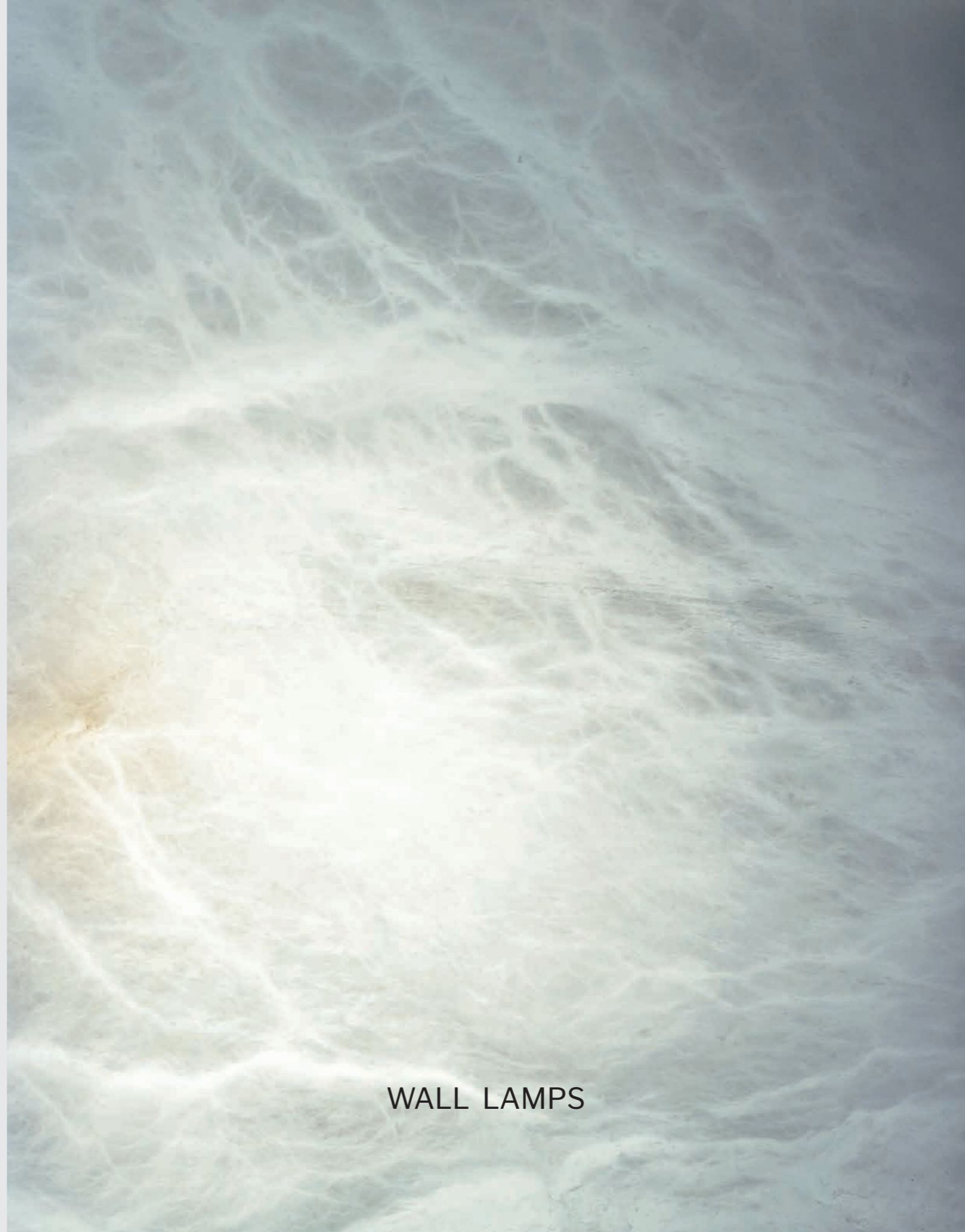
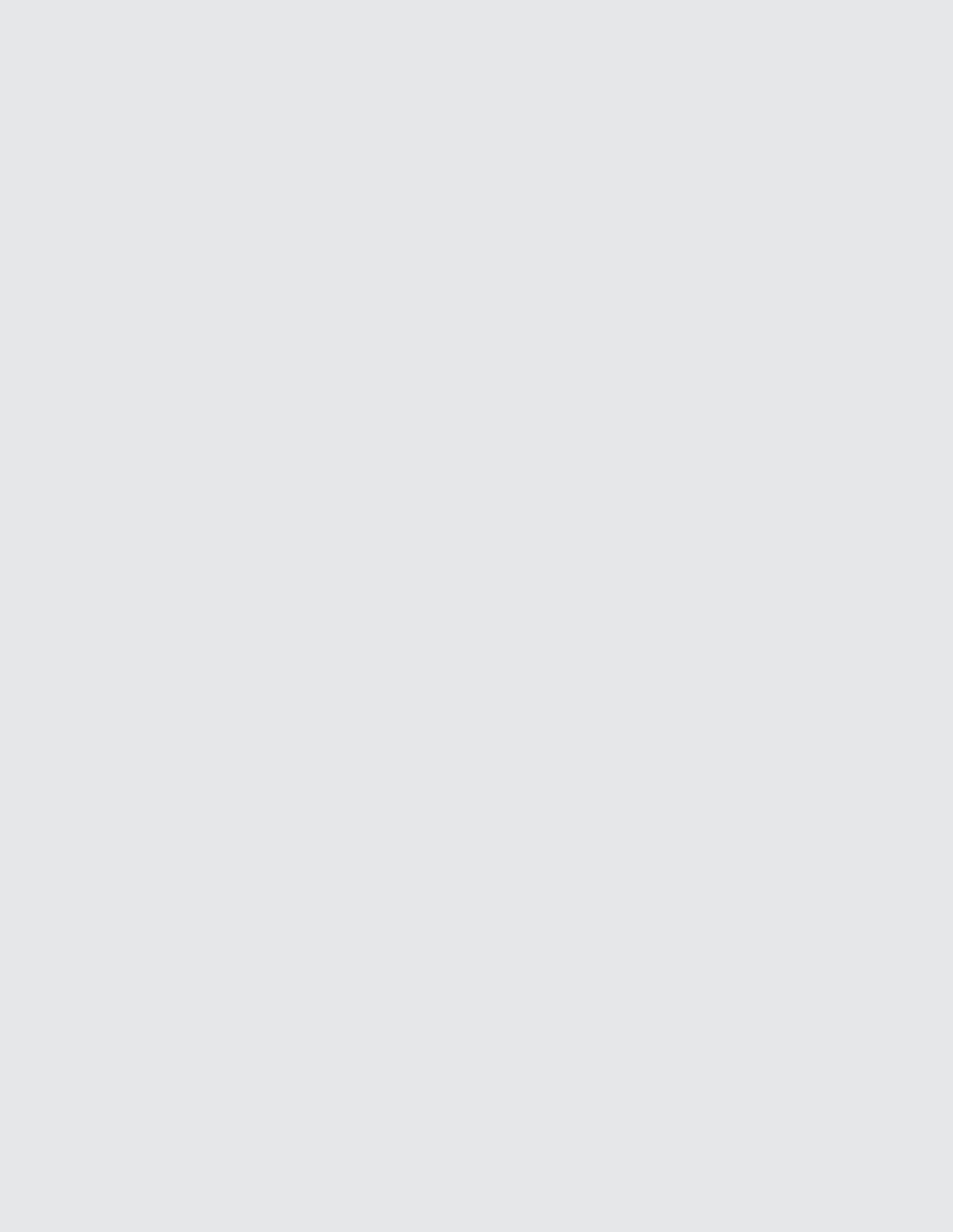

WALL LAMPS

Nuvol WS

Wall Lamp

Nuvol WS is composed of two overlapping alabaster stone discs, which generate a translucent effect and play with light to create a stunning visual experience. Nuvol is inspired by the organic forms of nature and the clouds in the sky.



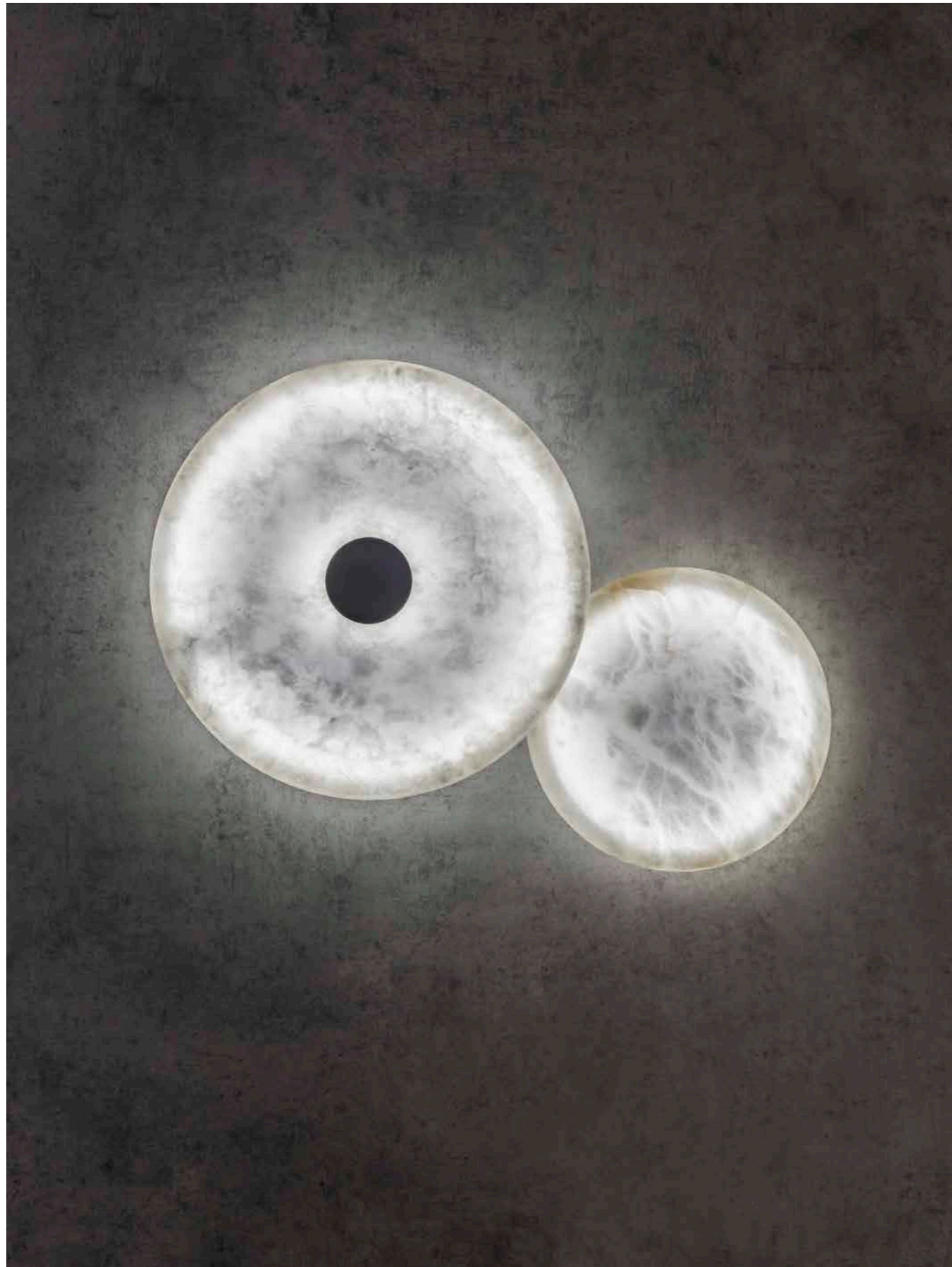



Nuvol WS

10-8777
Wall lamp

Technical Specs

Compact LED 6w
3000K

Structure

-  Nickel
-  Black Nickel
-  Gold

Alabaster

-  White Gelsa

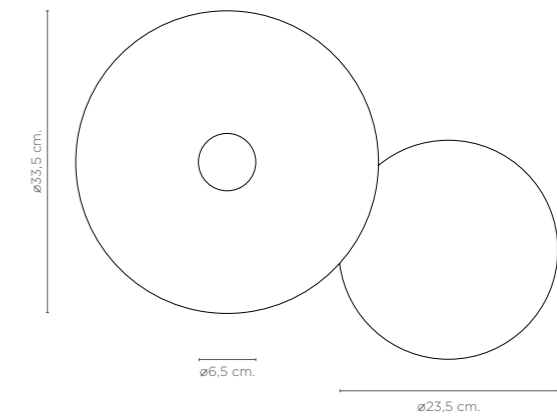

Slim WS

Wall Lamp

Minimalist wall sconce, giving a subtle touch to any style of decoration with the possibility of applying several, creating a rhythm in each point of light. Designed by Joan Casanyes.





Slim WS





10-9540/32/64/96
Wall lamp

Technical Specs

LED stripe 3000K or 2700K
230-240v
Optional: Driver dimmable
32cm - 4w
64cm - 8w
96cm - 12w

Sizes:
6 x 32 cm.
6 x 64 cm.
6 x 96 cm.

Structure

-  Satin Nickel
-  Black Nickel
-  Satin Gold
-  Matt Black
-  Dark bronze

Alabaster

-  White Gelsa

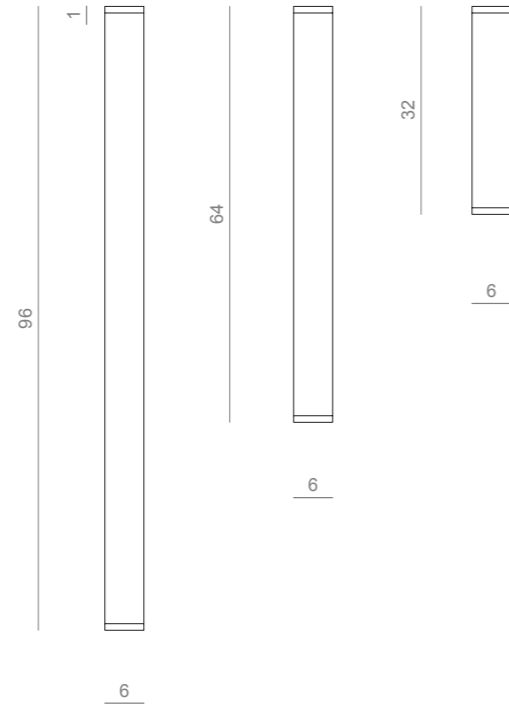

Mirror

Wall Lamp

Wavy alabaster discs combine with mirrored and marble discs to create play of light and reflections. Luminaires that slightly protrude from the walls or ceilings where they are installed. By forming groups of Mirror Disc in different sizes, indirect, diffuse and also reflected light effects are achieved through the mirrors. Designed by Joan Casanyes.





Mirror

10-9570/48 - 10-9570/64 - 10-9570/80
Wall lamp

Technical Specs

MIRROR DISC 10-9570/48

48 x 5,5 cm.
 Linear LED with aluminum support
 18w 3000K
 Driver 25w 230-24v

MIRROR DISC 10-9570/64

64 x 5,5 cm.
 Linear LED with aluminum support
 24w 3000K
 Driver 25w 230-24v

MIRROR DISC 10-9570/80

80 x 5,5 cm.
 Linear LED with aluminum support
 30w 3000K
 Driver 35w 230-24v

Structure

 Matt White (RAL 9010)

 Mirror

Alabaster

 White Gelsa

10-9570/48

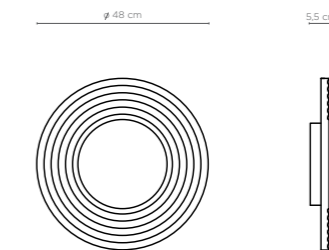

10-9570/64

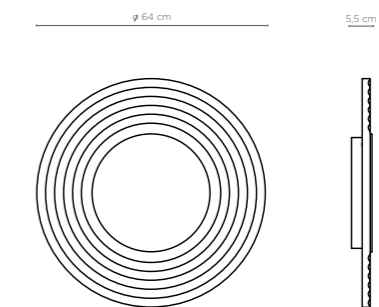

10-9570/80

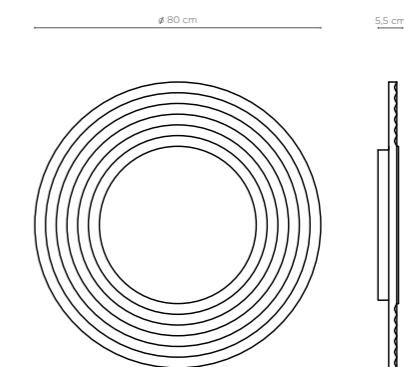

AD 1930

Wall Lamp

Vertical format wall light, perfect for contract lighting. Its surface lets the alabaster veins shine perfectly, giving a premium touch to the environment.









AD 1930

10-9670
Wall lamp

Technical Specs

2 x LED linear light 10w 3000k
Available configuration LED 2700K
15 x 70 cm

Structure

-  Satin Nickel
-  Black Nickel
-  Satin Gold
-  Matt Black

Alabaster

-  White Gelsa

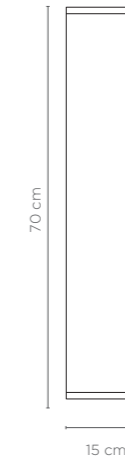



Slim Collection

Wall Lamp

The Slim Collection wall light has added semi-circular mirrors on each side. Currently, the mirror is an element that is incorporated into interiors, and the set is an elegant decorative complement, suitable for a multitude of spaces.





Slim Collection





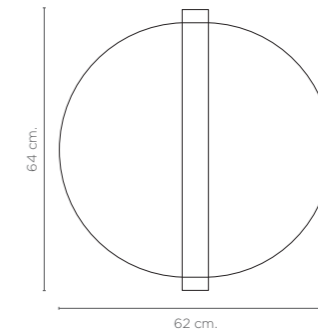

10-9648
Wall lamp

Technical Specs

LED strip 3000K or 2700K
230-240v
Optional: Driver dimmable
64cm - 8w
D. 62 x 64 cm



Structure

-  Satin Nickel
-  Black Nickel
-  Satin Gold
-  Mirror
-  Matt Black
-  Dark bronze

Alabaster

-  White Gelsa

Berlin

Wall Lamp

With the Berlin Collection the concepts have been update by using alabaster as a diffusing material of light. This collection is perfect to be installed in much more modern and minimalist designs, being the latest fashion in design and interior design.









Berlin2

20-8648/2
Wall Lamp

Technical Specs

LED 3,5w 3000K G9
H. 66 x 22 cm

Structure

-  Satin Gold
-  Satin Nickel
-  Black Nickel
-  Brass

Alabaster

-  White Gelsa

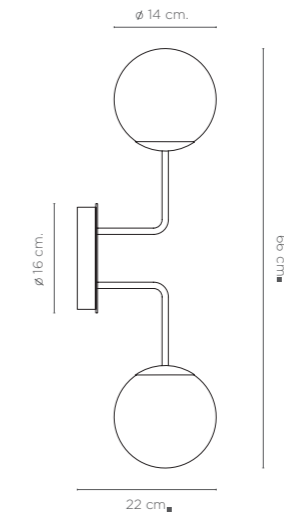

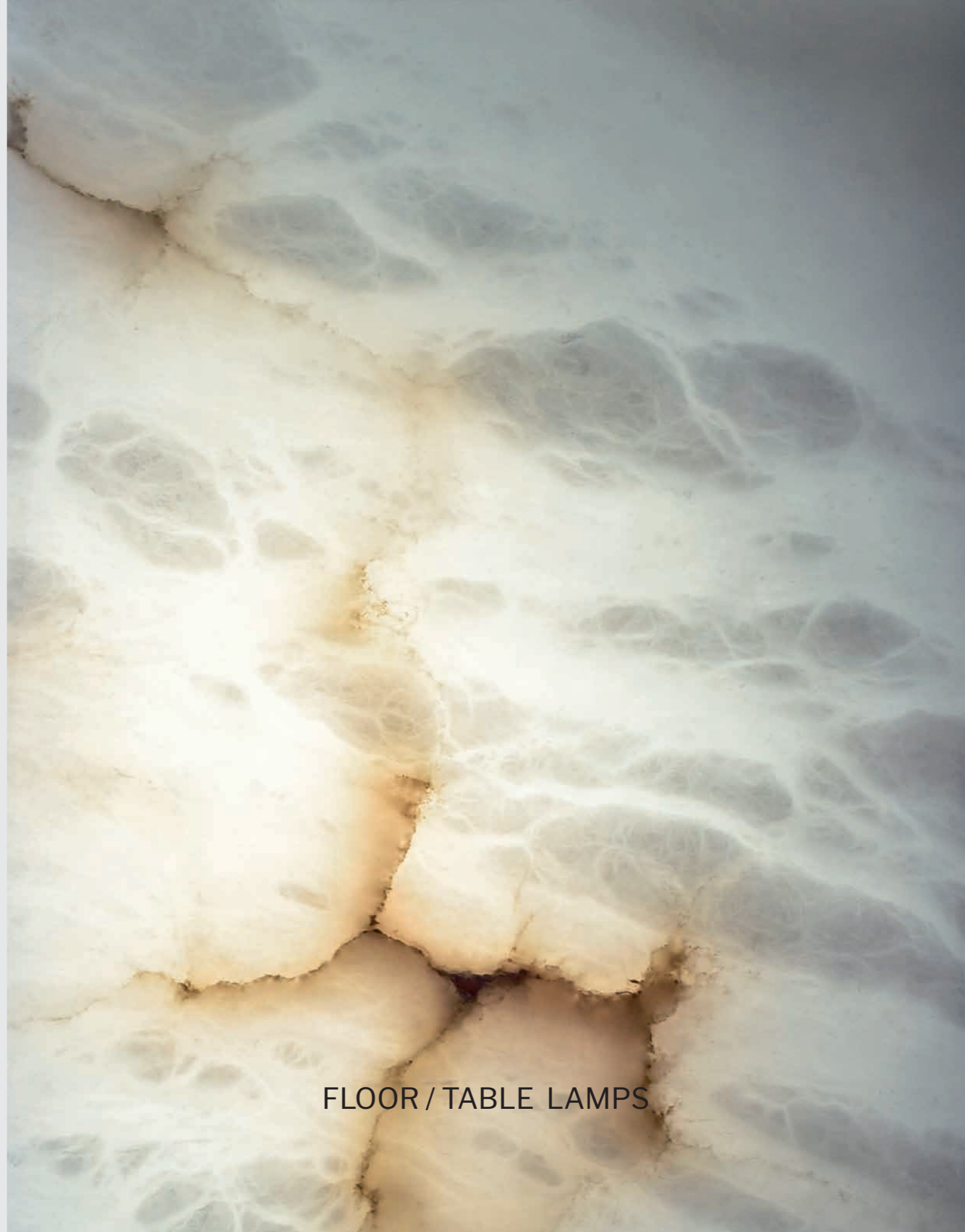
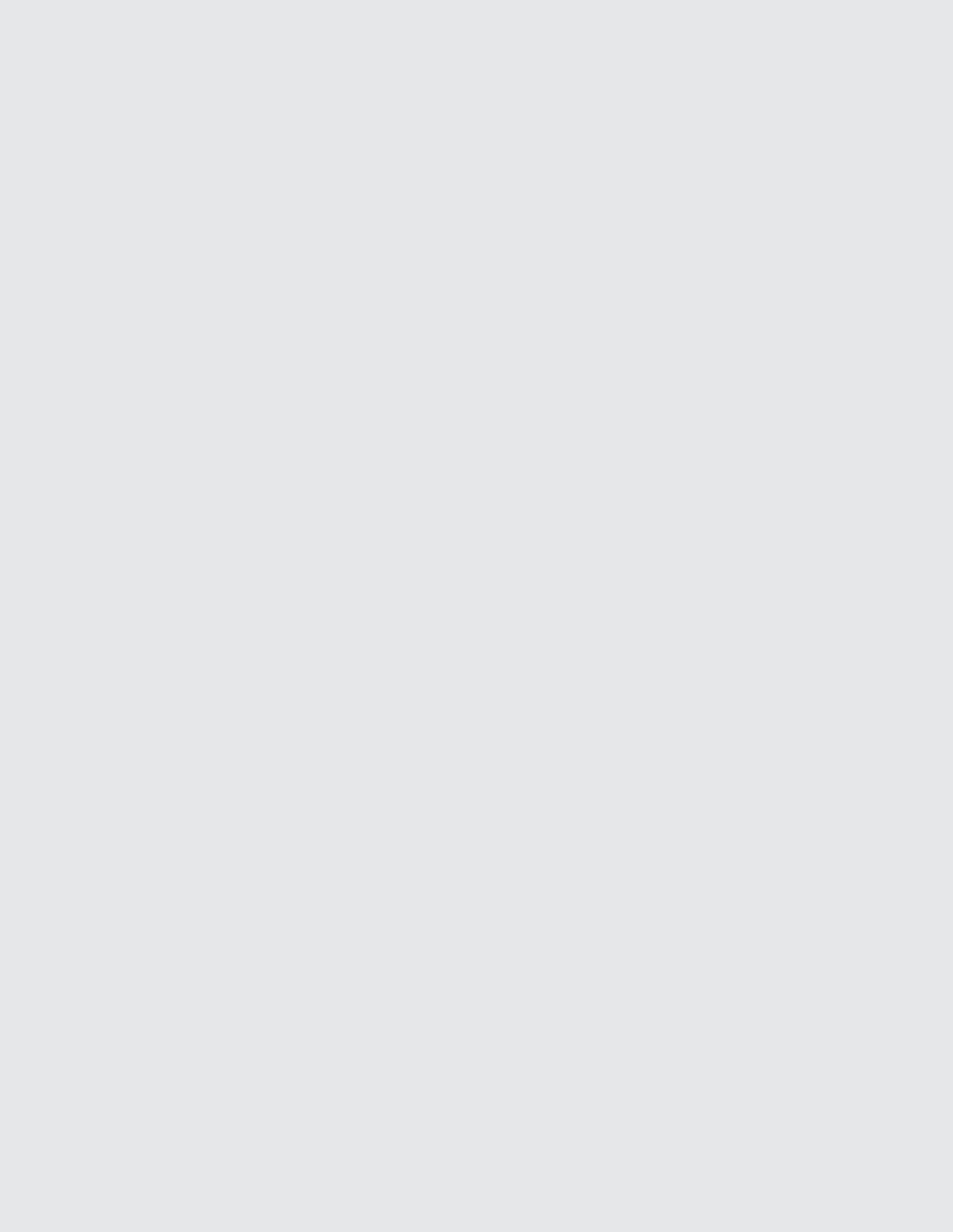

FLOOR / TABLE LAMPS

Solaris

Table Lamp

Table composed of an alabaster sphere mounted on a polished metal disc, it produces duplicated reflections. The glass shade allows the pleasant luminous effect of striped lights and reflections produced by the alabaster.





Solaris

CTS-2530W
Table lamp

Technical Specs

LED Bulb E27
15W
2700K dimmable

Base

Chrome

Black Nickel

Gold

Alabaster

White Gelsa

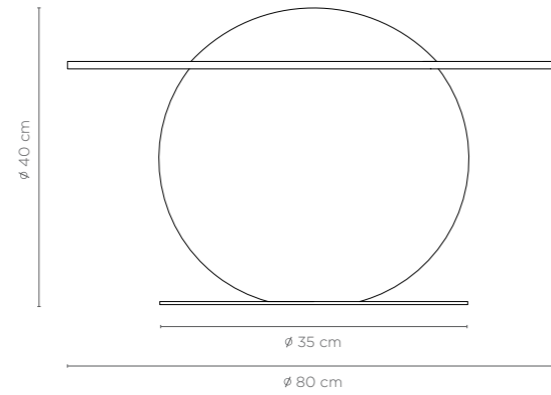

Solaris

CTS-2520W
Table lamp

Technical Specs

LED Bulb E27
15W
2700K dimmable

Base

Chrome

Black Nickel

Gold

Alabaster

White Gelsa

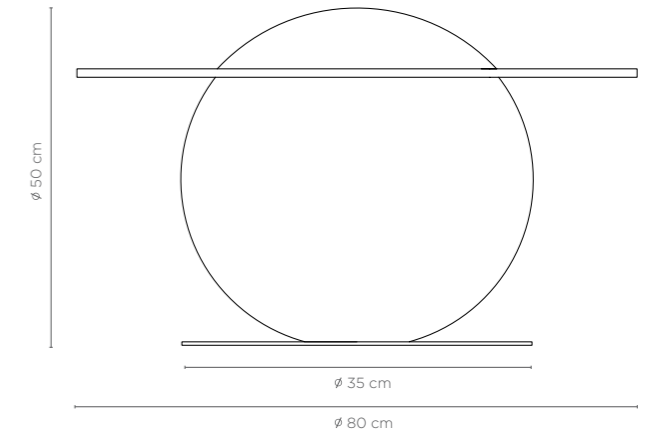

Wireless Moon

Floor Lamp

The Slim Collection wall light has added semi-circular mirrors on each side. Currently, the mirror is an element that is incorporated into interiors, and the set is an elegant decorative complement, suitable for a multitude of spaces.





Wireless Moon

50-7000
Floor lamp

Technical Specs

LED 3W 290lm 3000K
Built in led battery module (5200mAh)
Indoor and outdoor use (IP44)

50-7000/18 D. 18 cm

50-7000/24 D. 24 cm

Base

 Matt white

Alabaster

 White Gelsa

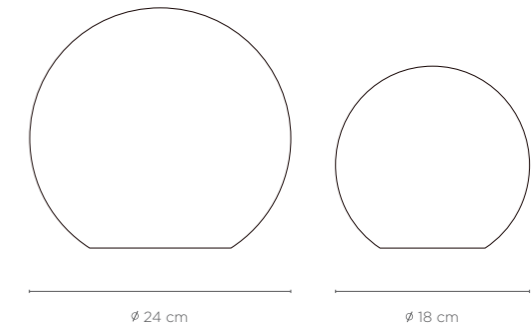



Wireless Oval

50-7010
Floor lamp

Technical Specs

LED 3W 290lm 3000K
Built in led battery module (5200mAh)
Indoor and outdoor use (IP44)

50-7010/18 D. 18 x 11,5 cm

50-7010/28 D. 28 x 17,5 cm

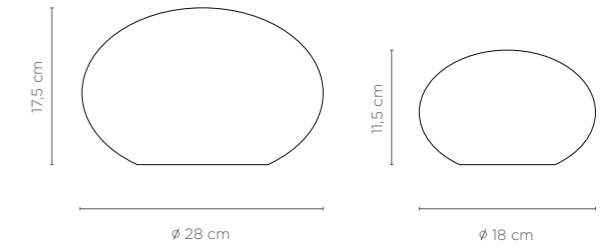

Base

 Matt white

Alabaster

 White Gelsa

Wireless Glans

Table Lamp

Wireless Glans was born from the need to make one of our most iconic models a new design. The organic shape of the acorn-shaped alabaster makes this design a special piece. The technical and aesthetic innovation in this design, its metal ring and its wireless system allows us to illuminate any of our spaces in our home with a warm light. Designed by Joan Casanyes.







Wireless Glans

50-7030
Table lamp

Technical Specs

LED 3W 290lm 3000K
Built in led battery module (5200mAh)
Indoor and outdoor use (IP44)

Structure

-  Satin Nickel
-  Satin Black Nickel
-  Brushed Brass

Alabaster

-  White Gelsa

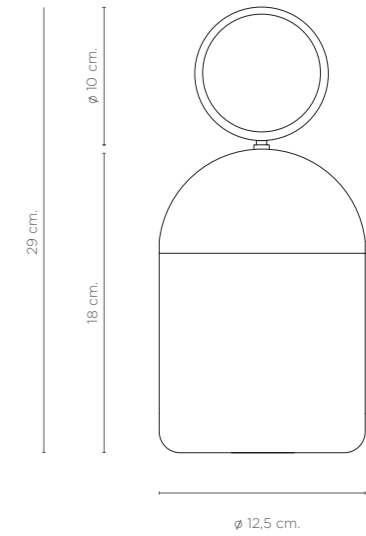



Reflex

Floor/table Lamp

Alabaster ellipse mounted on a metal disc, produces duplicate reflections. The black Marquina marble base. Versatile and avant-garde for any public or private environment.







Reflex

50-9586
Table lamp



Technical Specs

G9 LED 3,5w 3000K
18 x 71 cm.

Structure

-  Nickel
-  Black Nickel
-  Gold

Base

-  Brown Sarral Alabaster
-  Black Marquina Marble

Alabaster

-  White Gelsa

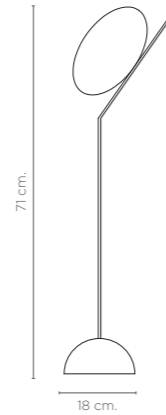



Reflex

50-9585
Floor lamp



Technical Specs

G9 LED 3,5w 3000K
28 x 184 cm.

Structure

-  Nickel
-  Black Nickel
-  Gold

Base

-  Brown Sarral Alabaster
-  Black Marquina Marble

Alabaster

-  White Gelsa

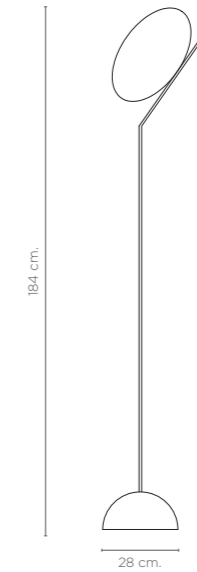

Saturn Cycle

Table Lamp

Alabaster sphere mounted on a polished metal disc, produces duplicate reflections. By installing a group of luminaires on the wall or ceiling, a pleasant light effect of streaked lights and reflections is produced.





Saturn Cycle

50-3999
Table lamp

Technical Specs

G9 LED 2,5w 3000K
20 x 28 cm.

Structure

 Nickel

 Black Nickel

 Gold

Base

 Brown Sarral Alabaster

Alabaster

 White Gelsa

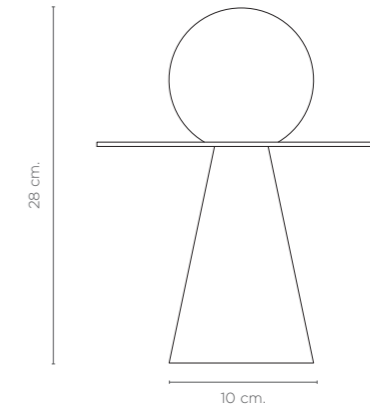

Hexagon

Table Lamp

The contradiction of the organic forms with the straight lines unites these two polygons creating an ambient table light with art deco characteristics. Two types of alabaster stone are combined: one translucent and the other opaque.





Hexagon

50-3900
Table lamp

Technical Specs

G9 LED 2,5w 3000K
27 x 27 x 10 cm
D. 16 cm shade

Structure

 Nickel

 Black Nickel

Base

 Brown Sarral Alabaster

Alabaster

 White Gelsa

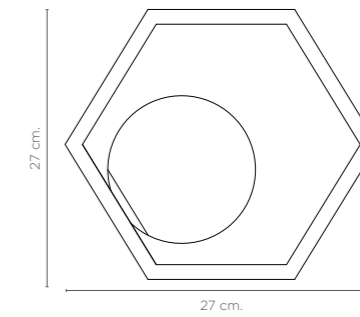



CUSTOM DESIGNS

Front Desk

Custom Design

Modular reception furniture fully adaptable to any contract project. Backlit wavy cut alabaster plates, with a great visual presence. Oak plinth and top in natural matte finish.





Wavy Desk

RD-7500-W
Custom Design

Technical Specs

LIGHT SYSTEM
Back-lit panel based on LED linear light
Light color 3000K 24v
Drivers 230-24v
100 x 50 x 110 cm./each panel

Top and Base

■ Matt lacquered natural Oak

Alabaster

■ White Gelsa

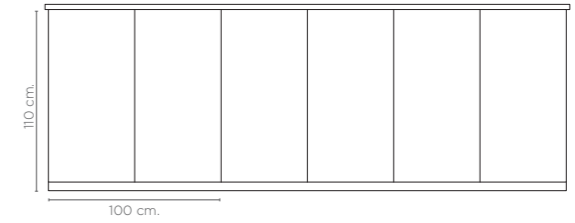



Panels

Custom Design

For custom projects where the light and the naturalness of the stone are the protagonists. Custom projects are carried out with illuminated panels pre-configured with led light, admirable to see. Its installation is made from a profiled structure of polished and satin stainless steel that acts as a support for the panels and facilitates their construction. They can be applied horizontally or vertically, and can be wavy or smooth. Each panel has its beauty and the whole set becomes a contemporary element for hotels, shops, airports or restaurants.





Panels

PC-9900-L
Custom Design

Technical Specs

LIGHT SYSTEM
Back-lit panel based on LED linear light
Light color 3000K at 24v
Drivers 230 - 24v.
30 x 54 cm each pannel

Structure

 Customized metal finishing

Alabaster

 White Gelsa

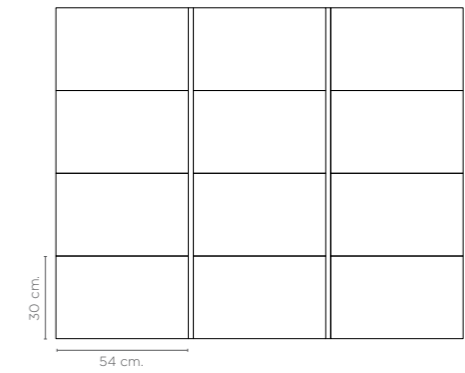

WE HAVE THE FORMULA
TO LIGHT UP YOUR COLLECTION
WITH ALABASTER



UNITED ALABASTER, DESIGNER LIGHTING IN ALABASTER SINCE 1969

United Alabaster creates unique designer lamps made from alabaster, exporting local craftsmanship around the world.

Creativity, design and innovation define this project with more than 50 years of experience, hard work and perseverance.

Exhaustive quality controls and historical origin guarantee the material through its geographical location. The material, which is extracted in big balls, is sent to the sawmill where we clean and cut the material to prepare it in different formats for its processing in the alabaster workshops.

The Gelsa alabaster extracted from an original vein in the quarry is moulded by the craftsmen's hands of United Alabaster to shape them.

The application of alabaster to the new architecture, allow us to create big walls for any type of form that improve the elegant translucent effects of this material.

We propose the union of a historical natural stone with contemporary elements, metals, wall and ceiling linings, cutting-edge lighting designs. Alabaster, metal or wood structures, finishes, all originates from a whole, without forgetting the great responsibility to reach the ideal combination for each project.

In addition to the product catalogue, United Alabaster carries out customised projects. Customers send their proposals and the technical team assesses the feasibility and offers solutions to make everything imaginable a reality.

The company makes custom-made lighting projects in lamps, alabaster panels and alabaster plates, in all types of environments and rooms in the most important cities all over the world.

Definitively it is a surprising material for the current interior designs.

Get inspired to design your world!



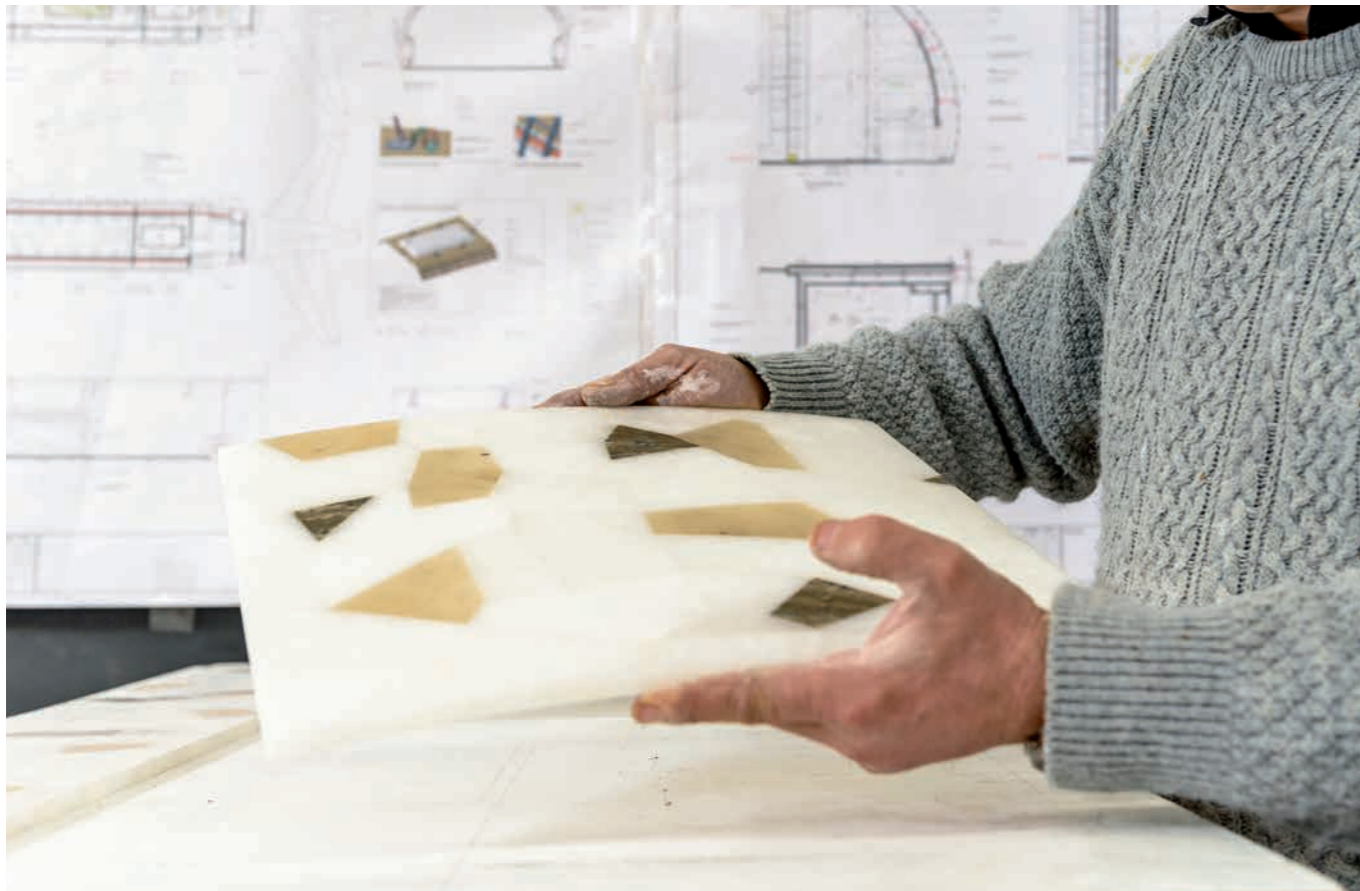

Headquarter Offices
Anna Meroño
info@unitedalabaster.com

Camí de Sarral a Barberà, s/n
Sarral
TARRAGONA -Spain-
+34 977 890 680
+34 636 549 967

www.unitedalabaster.com

Quarries Offices
P.I. Venta del Barro, s/n
La Puebla del Hijar
TERUEL -Spain-
+34 978 821 347

Project Manager
Carlos Salvador
support@unitedalabaster.com

Art Director
Marc Velasco
marketing@unitedalabaster.com

Photographer
Pep Escoda

Product Design
Joan Casanyes
Own team

Writer
Marta Huguet

Graphic Design
Dosidesign

www.instagram.com/unitedalabaster
www.facebook.com/unitedalabaster

